

Report of Test

LLIA001329-009A

Indoor Distribution Photometry Test Report

Catalog Number: PS5-A-HO-K35-80-4-XX-WTR-LOH-XXXV

Recessed mounted, extruded aluminum housing, formed white enamel aluminum LED tray, translucent white plastic enclosure.

144 white LEDs, two Osram PrevaLED Bars with 72 LEDs each.

One Osram Optotronic OTi 30/120-277/1A0 DIM-1 L G2LED driver labeled as 840mA

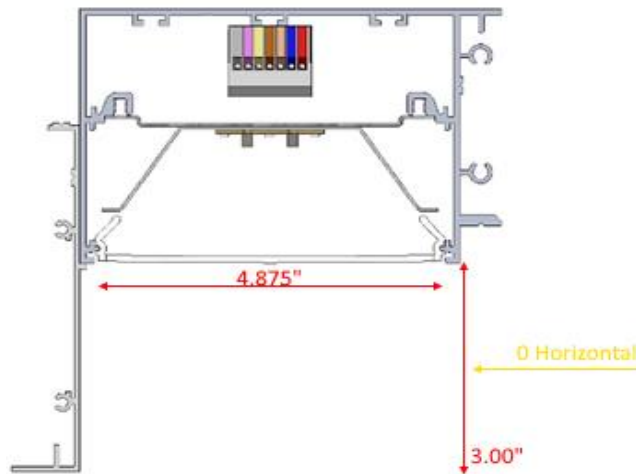

Prepared For:

Precision Architectural Lighting
4830 Timber Creek Drive
Houston, TX 77017, USA

Performance Summary			
Input Voltage	120.0 V	Luminous Flux	3504.2 Lumens
Input Current	0.2667 A	Total Efficacy	110.6 Lm/W
Input Power	31.68 W	Downward Flux	3416.4 Lumens
Frequency	60.00 Hz	Downward Flux	97.5 % of Total
Power Factor	0.990		
Current THD	6.5 %		

This test report was issued by LightLab International Allentown, LLC without alterations or erasures.

Test date: 10/13/2020

Report date: 10/14/2020

Signed: _____

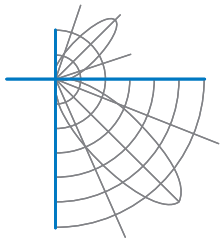

Report of Test
LLIA001329-009A

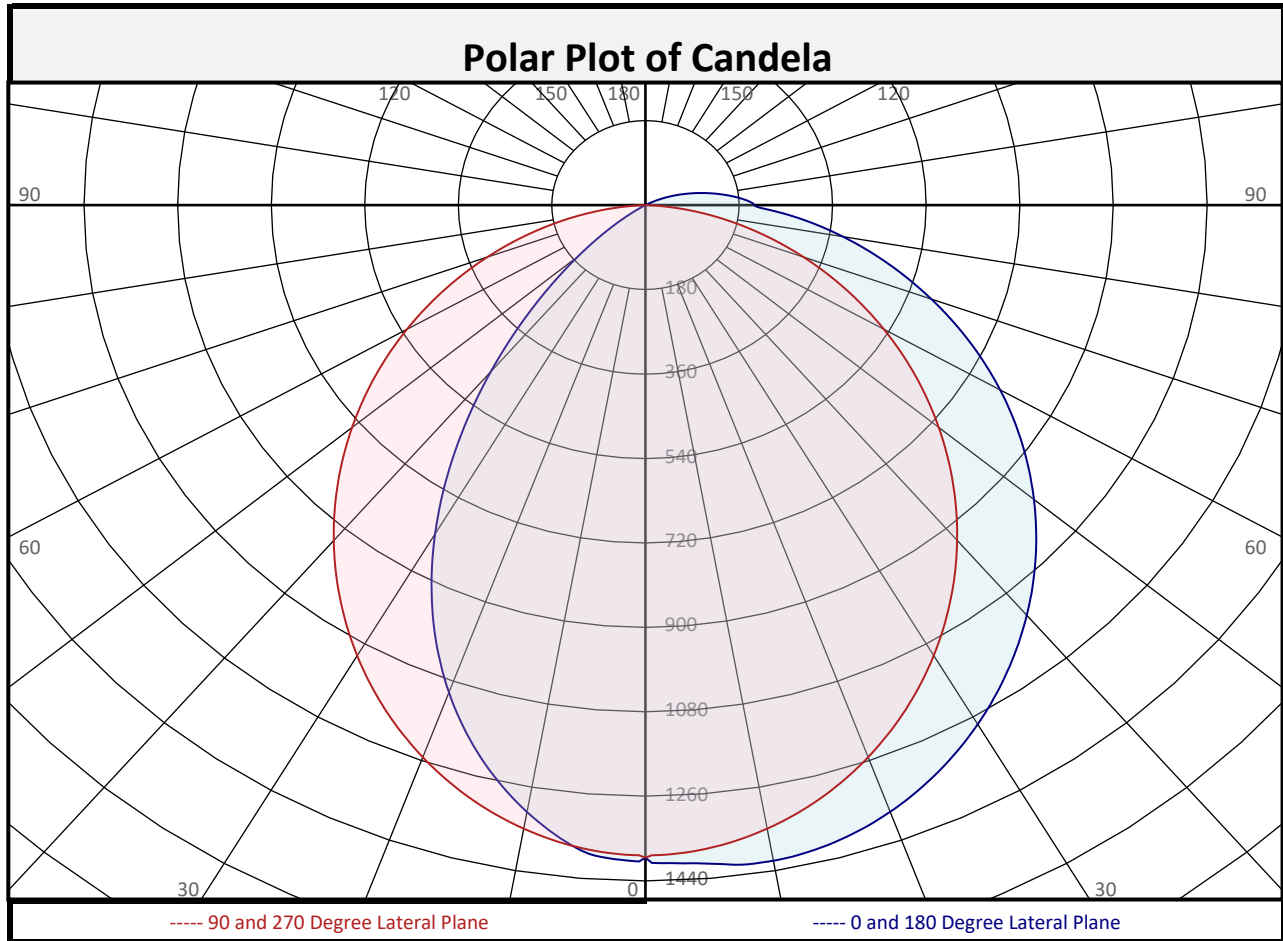

Zonal Flux Summary										
Zone (Deg Vert)	Flux (Lumens)	Percent of Total		Zone (Deg Vert)	Flux (Lumens)	Percent of Total		Zone (Deg Vert)	Flux (Lumens)	Percent of Total
0-10	131.4	3.7%		90-100	56.2	1.6%		0-20	500.7	14.3%
10-20	369.3	10.5%		100-110	25.0	0.7%		0-30	1039	29.7%
20-30	538.1	15.4%		110-120	5.4	0.2%		0-40	1649	47.1%
30-40	610.4	17.4%		120-130	1.0	0.0%		0-60	2716	77.5%
40-50	583.5	16.7%		130-140	0.3	0.0%		0-80	3300	94.2%
50-60	483.4	13.8%		140-150	0.0	0.0%		10-90	3285	93.7%
60-70	354.3	10.1%		150-160	0.0	0.0%		20-50	1732	49.4%
70-80	229.4	6.5%		160-170	0.0	0.0%		40-90	1767	50.4%
80-90	116.7	3.3%		170-180	0.0	0.0%		60-90	700.3	20.0%
0-90	3416	97.5%		90-180	87.8	2.5%		0-180	3504	100.0%

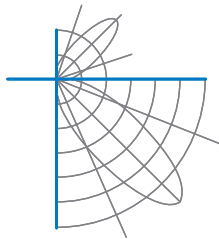

Report of Test

LLIA001329-009A

Luminous Intensity (Candela) Table

		Lateral (C-Plane) Angles								
		0	22.5	45	67.5	90	112.5	135	157.5	180
Vertical (Gamma) Angles	0	1391	1391	1391	1391	1391	1391	1391	1391	1391
	2.5	1404	1398	1391	1386	1383	1382	1385	1391	1395
	5	1409	1401	1389	1381	1376	1375	1377	1381	1382
	7.5	1418	1408	1388	1372	1365	1362	1358	1352	1351
	10	1419	1409	1387	1360	1349	1347	1329	1317	1313
	12.5	1415	1404	1380	1346	1330	1324	1294	1276	1270
	15	1406	1394	1368	1330	1308	1295	1255	1229	1221
	17.5	1393	1381	1351	1312	1281	1261	1211	1178	1166
	20	1376	1363	1331	1290	1252	1223	1164	1121	1105
	22.5	1356	1342	1308	1263	1220	1183	1113	1060	1039
	25	1333	1318	1281	1234	1186	1139	1058	994	968
	27.5	1307	1291	1252	1202	1148	1093	1000	922	891
	30	1278	1261	1220	1167	1109	1045	938	846	810
	32.5	1247	1229	1185	1130	1068	995	873	767	725
	35	1214	1195	1149	1090	1024	942	806	685	637
	37.5	1179	1159	1111	1050	979	889	736	601	549
	40	1141	1121	1071	1007	933	833	664	516	462
	42.5	1102	1082	1030	963	885	776	590	434	379
	45	1062	1040	987	918	836	719	516	354	300
	47.5	1019	998	944	872	787	660	441	280	230
50	976	954	899	825	737	600	368	213	167	
52.5	931	908	853	777	685	539	297	153	113	
55	884	862	807	729	634	477	231	102	67	
57.5	837	815	759	681	582	415	171	59	28	
60	788	767	712	632	530	353	118	23	0	
62.5	738	717	663	583	478	290	73	4	0	
65	687	667	614	534	426	229	36	3	0	
67.5	637	616	565	485	374	171	8	3	0	
70	585	566	515	437	323	117	6	3	0	
72.5	535	515	465	389	274	70	5	2	0	
75	484	465	414	342	225	33	4	0	0	
77.5	434	416	366	294	177	9	3	0	0	
80	385	368	318	245	131	7	3	0	0	
82.5	337	321	272	198	87	5	0	0	0	
85	289	274	227	154	44	3	0	0	0	
87.5	240	226	181	112	13	0	0	0	0	
90	210	195	146	73	0	0	0	0	0	

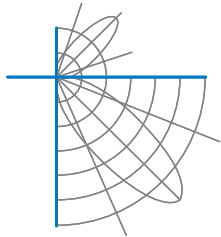

Report of Test

LLIA001329-009A

Luminous Intensity (Candela) Table

		Lateral (C-Plane) Angles								
		0	22.5	45	67.5	90	112.5	135	157.5	180
Vertical (Gamma) Angles	90	210	195	146	73	0	0	0	0	0
	92.5	198	183	133	60	0	0	0	0	0
	95	180	164	115	44	0	0	0	0	0
	97.5	160	144	97	30	0	0	0	0	0
	100	140	124	78	17	0	0	0	0	0
	102.5	119	105	61	8	0	0	0	0	0
	105	99	85	44	7	0	0	0	0	0
	107.5	79	67	29	6	0	0	0	0	0
	110	61	49	14	5	0	0	0	0	0
	112.5	43	32	6	4	0	0	0	0	0
	115	26	16	6	4	0	0	0	0	0
	117.5	10	4	5	3	0	0	0	0	0
	120	0	3	4	3	0	0	0	0	0
	122.5	0	3	4	3	0	0	0	0	0
	125	0	3	3	2	0	0	0	0	0
	127.5	0	2	3	2	0	0	0	0	0
	130	0	2	3	2	0	0	0	0	0
	132.5	0	2	3	0	0	0	0	0	0
	135	0	0	2	0	0	0	0	0	0
	137.5	0	0	2	0	0	0	0	0	0
140	0	0	0	0	0	0	0	0	0	
142.5	0	0	0	0	0	0	0	0	0	
145	0	0	0	0	0	0	0	0	0	
147.5	0	0	0	0	0	0	0	0	0	
150	0	0	0	0	0	0	0	0	0	
152.5	0	0	0	0	0	0	0	0	0	
155	0	0	0	0	0	0	0	0	0	
157.5	0	0	0	0	0	0	0	0	0	
160	0	0	0	0	0	0	0	0	0	
162.5	0	0	0	0	0	0	0	0	0	
165	0	0	0	0	0	0	0	0	0	
167.5	0	0	0	0	0	0	0	0	0	
170	0	0	0	0	0	0	0	0	0	
172.5	0	0	0	0	0	0	0	0	0	
175	0	0	0	0	0	0	0	0	0	
177.5	0	0	0	0	0	0	0	0	0	
180	0	0	0	0	0	0	0	0	0	

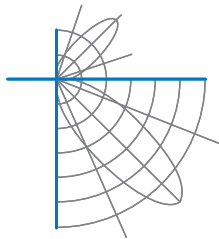

Report of Test

LLIA001329-009A

Coefficients of Utilization/Room Utilization - Zonal Cavity Method																							
Effective Floor Cavity Reflectance 0.20																							
RC	80					70					50				30				10			0	
RW	70	50	30	10		70	50	30	10		50	30	10		50	30	10		50	30	10	0	
RCR																							
0	118	118	118	118		115	115	115	115		110	110	110		105	105	105		100	100	100		97
1	108	103	99	95		105	101	97	93		96	93	90		91	89	86		87	85	83		81
2	98	90	83	78		96	88	82	77		84	79	74		81	76	72		77	74	70		68
3	90	80	72	65		87	78	70	64		75	68	63		72	66	62		69	64	60		58
4	83	71	62	56		80	69	61	55		67	60	54		64	58	53		62	56	52		50
5	76	64	55	48		74	62	54	48		60	53	47		58	52	47		56	50	46		44
6	71	58	49	43		69	57	48	42		54	47	42		53	46	41		51	45	41		39
7	66	52	44	38		64	52	43	38		50	42	37		48	42	37		47	41	36		34
8	61	48	40	34		60	47	39	34		46	39	33		44	38	33		43	37	33		31
9	57	44	36	31		56	43	36	31		42	35	30		41	35	30		40	34	30		28
10	54	41	33	28		52	40	33	28		39	32	28		38	32	27		37	31	27		25

For absolute test reports, RUs are expressed as a percentage of total lumen output. For relative test reports, CUs are expressed as a percentage of total lamp output. Calculations were based on published IES procedures, and are based on the zonal cavity method. Basic assumptions: 1) Room surfaces are lambertian reflectors. 2) Incident flux on each surface is uniformly distributed. 3) The room is spectrally neutral. When luminaires are not evenly distributed throughout the room, or do not exhibit lateral symmetry, CU values may differ from actual performance.

Circle of Light Plot				
Height(ft)	Illuminance at Nadir (fc)	Ground-level distance to half-of-nadir illuminance (ft)		
		0-180 deg	90-270 deg	
6.0	38.6	6.94	7.14	
8.0	21.7	9.26	9.53	
10.0	13.9	11.57	11.91	
12.0	9.7	13.89	14.29	
14.0	7.1	16.20	16.67	
16.0	5.4	18.52	19.05	

Average Luminance (cd/m ²)			
	0 deg Plane	45 deg Plane	90 deg Plane
0	9214	9214	9214
45	6157	6444	7835
55	5436	5744	7322
65	4645	4978	6675
75	3758	4040	5752
85	2735	2882	3312

Spacing Criterion	
0 degree plane:	1.4
90 degree plane:	1.2
180 degree plane:	1.0
270 degree plane:	1.2

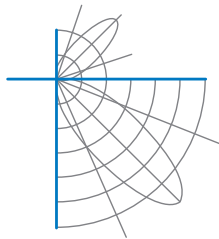

Report of Test

LLIA001329-009A

UGR TABLE - CORRECTED

Reflectances

Ceiling Cavity	70	70	50	50	30	70	70	50	50	30
Walls	50	30	50	30	30	50	30	50	30	30
Floor Cavity	20	20	20	20	20	20	20	20	20	20

Room Size		UGR Viewed Crosswise					UGR Viewed Endwise				
X=2H	Y=2H	20.2	21.8	20.6	22.1	22.5	16.5	18.0	16.9	18.4	18.8
	3H	22.5	23.9	23.0	24.3	24.7	17.8	19.2	18.3	19.6	20.0
	4H	23.6	24.9	24.0	25.3	25.7	18.3	19.6	18.7	20.0	20.4
	6H	24.6	25.8	25.0	26.2	26.7	18.5	19.7	19.0	20.1	20.6
	8H	25.0	26.2	25.5	26.6	27.1	18.6	19.7	19.0	20.2	20.6
	12H	25.5	26.6	26.0	27.0	27.5	18.6	19.7	19.1	20.1	20.6
4H	2H	20.6	21.9	21.1	22.3	22.8	17.1	18.4	17.6	18.8	19.3
	3H	23.1	24.2	23.6	24.7	25.1	18.7	19.8	19.2	20.3	20.7
	4H	24.3	25.3	24.8	25.8	26.3	19.3	20.3	19.8	20.7	21.2
	6H	25.5	26.3	26.0	26.8	27.3	19.6	20.5	20.2	21.0	21.5
	8H	26.0	26.8	26.5	27.3	27.9	19.7	20.5	20.2	21.0	21.6
	12H	26.6	27.3	27.1	27.8	28.4	19.8	20.5	20.3	21.0	21.6
8H	4H	24.5	25.3	25.0	25.8	26.3	19.8	20.6	20.3	21.1	21.6
	6H	25.8	26.4	26.3	27.0	27.5	20.3	21.0	20.8	21.5	22.0
	8H	26.4	27.0	27.0	27.6	28.1	20.4	21.1	21.0	21.6	22.2
	12H	27.1	27.7	27.7	28.2	28.8	20.5	21.1	21.1	21.6	22.3
12H	4H	24.5	25.2	25.0	25.7	26.3	19.9	20.6	20.4	21.1	21.7
	6H	25.8	26.4	26.3	26.9	27.5	20.5	21.1	21.0	21.6	22.2
	8H	26.5	27.0	27.0	27.6	28.2	20.7	21.2	21.2	21.8	22.4

Maximum UGR = 28.8

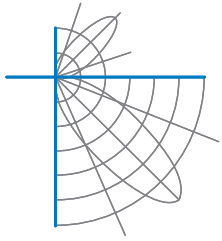

Report of Test
LLIA001329-009A

Iso-Illuminance Plot

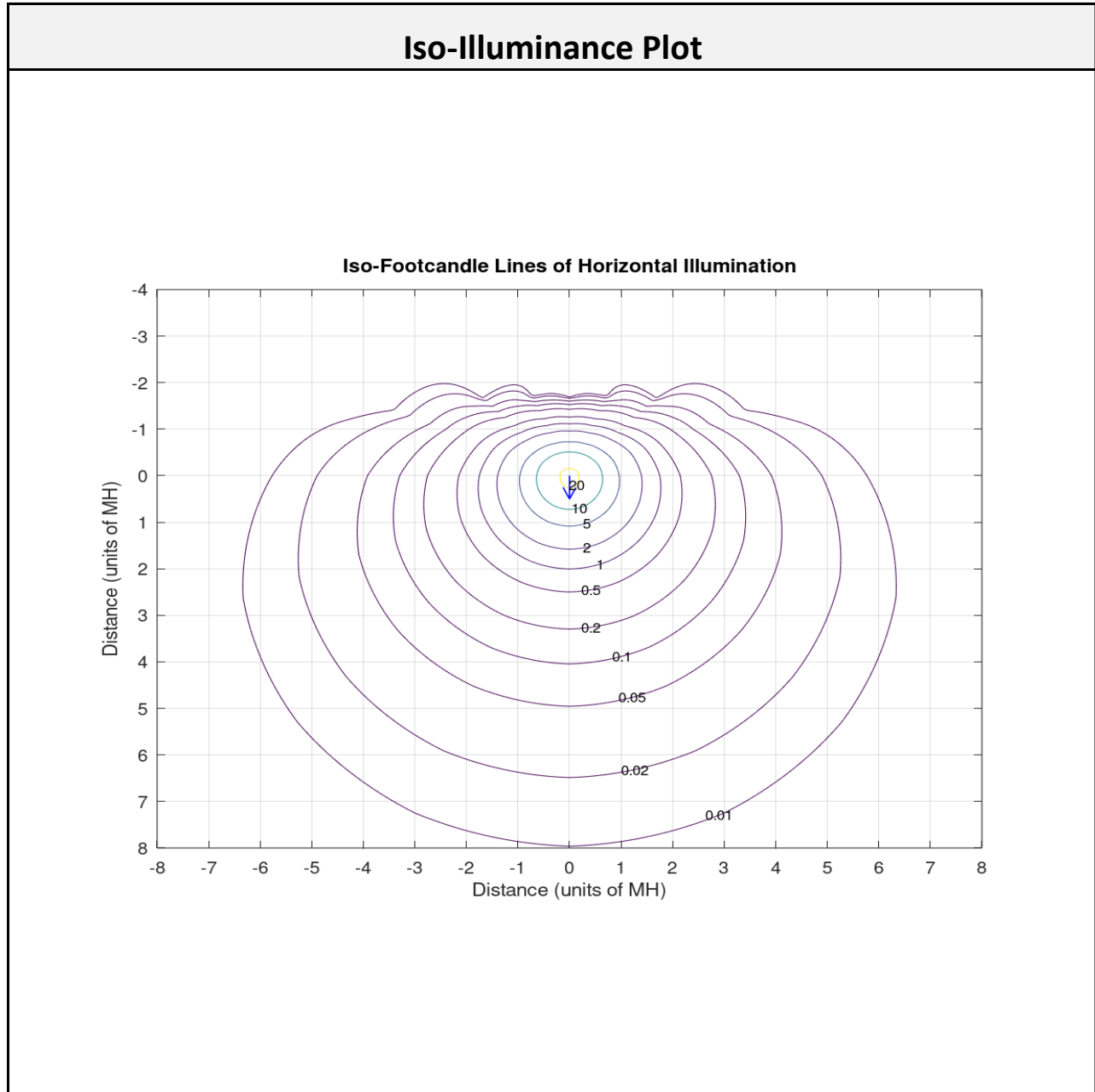

The isofootcandle values shown in the plot above are based on a mounting height of $h = 8.0$ feet. Grid values show multiples of mounting height. The isoilluminance contour lines are expressed in units of footcandles. The values expressed are based on the direct light from a single unit without the contribution of room reflections.

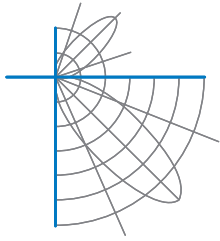

Report of Test
LLIA001329-009A

Additional Pictures of Test Subject

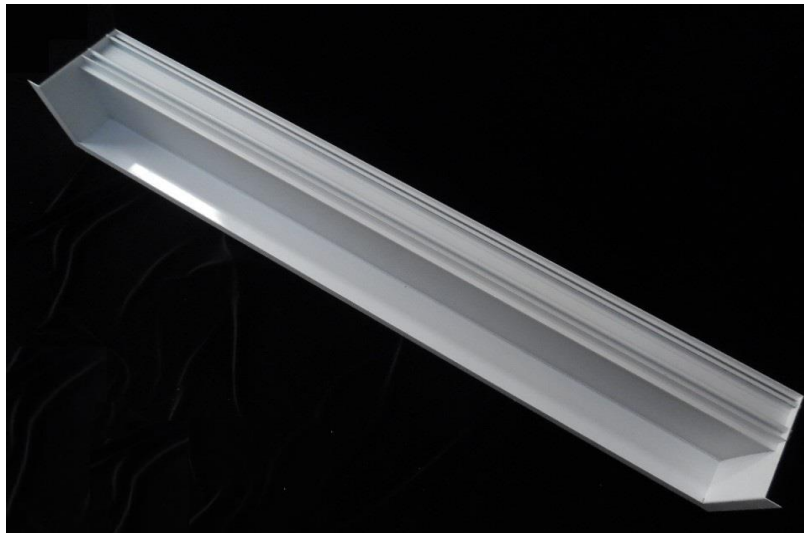

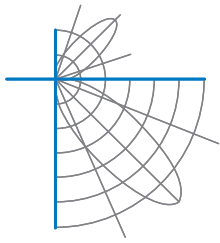

Report of Test

LLIA001329-009A

Test Distance 9.5 m
Ambient Temperature 24.7 °C

Notes

The laboratory has not participated in the selection of samples to be tested. All testing is performed on the understanding that the significance of the report is limited to the extent that the test sample is representative of production units.

Tested in accordance with the applicable sections of IES LM-79-19. Format of reports and angular increments based on IES LM-41-14 and LM-46-04.

The luminous intensity values, and other derived quantities, contained in this report are based on the absolute data, as measured.

Prorating the performance of the sample for the use of other component combinations (such as lamp / LED / Ballast / driver), or for use in different environmental conditions than that tested, may produce erroneous results.

This report is free of erasures and corrections.

Photometric intensity values are reported using the CIE C-Gamma coordinate system as defined in CIE publication number 121.

This report may contain data that are not covered by the NVLAP accreditation. Quantities marked with ‡ are not covered.

This report must not be used by the customer to claim product certification, approval or endorsement by NVLAP, NIST, or any agency of the Federal Government.

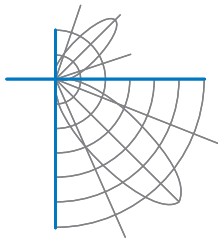

Report of Test

LLIA001329-009B

Integrating Sphere Report

Catalog Number: PS5-A-HO-K35-80-4-XX-WTR-LOH-XXXV

Recessed mounted, extruded aluminum housing, formed white enamel aluminum LED tray, translucent white plastic enclosure.

144 white LEDs, two Osram PrevaLED Bars with 72 LEDs each.

One Osram Optotronic OTi 30/120-277/1A0 DIM-1 L G2LED driver labeled as 840mA

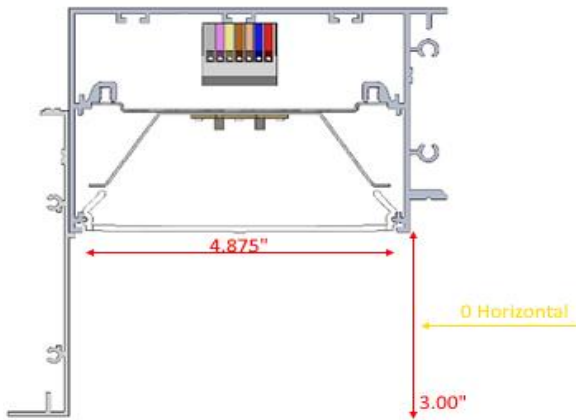

Performance Summary

Voltage	120.0 Vac
Current	0.2670 A
Power	31.65 W
Frequency	59.97 Hz
Power Factor	0.988
Current THD	6.6 %
Total Luminous Flux	3528.7 lm
Efficacy	111.5 lm/W
Chromaticity (x,y)	(0.4040, 0.3864)
(u',v')	(0.2367, 0.5093)
Duv	-0.0016
CCT	3492 K
CRI (Ra)	84
R9	15
TM-30: Rf	83
TM-30: Rg	96

Prepared For:

Precision Architectural Lighting
4830 Timber Creek Drive
Houston, TX 77017, USA

Test date: 10/12/2020

Report date: 10/14/2020

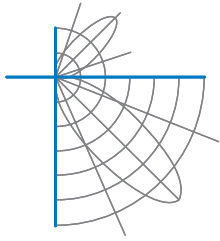

Test Report Number: LLIA001329-009B

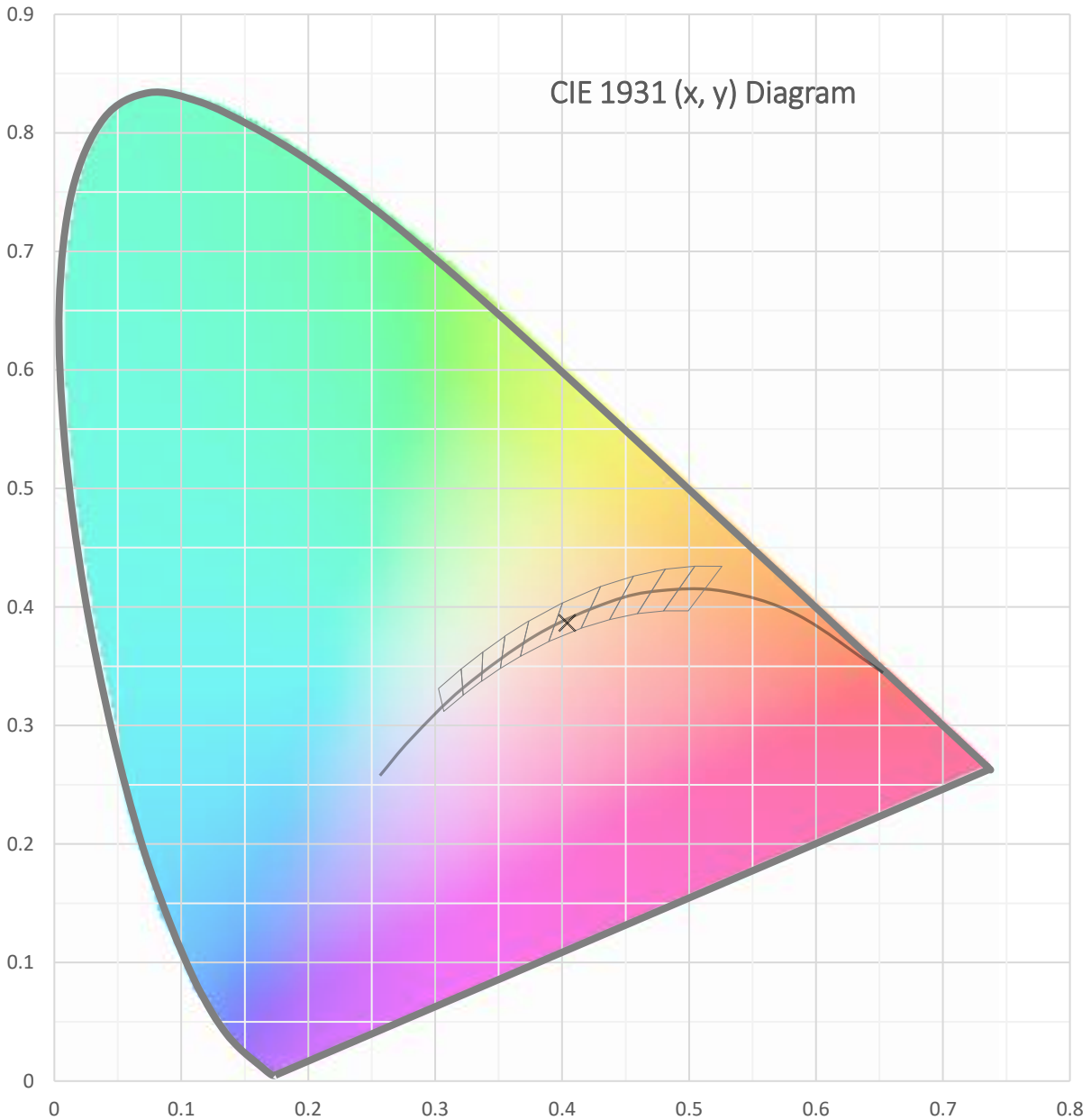

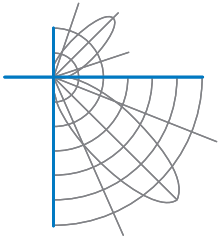

Test Report Number: LLIA001329-009B

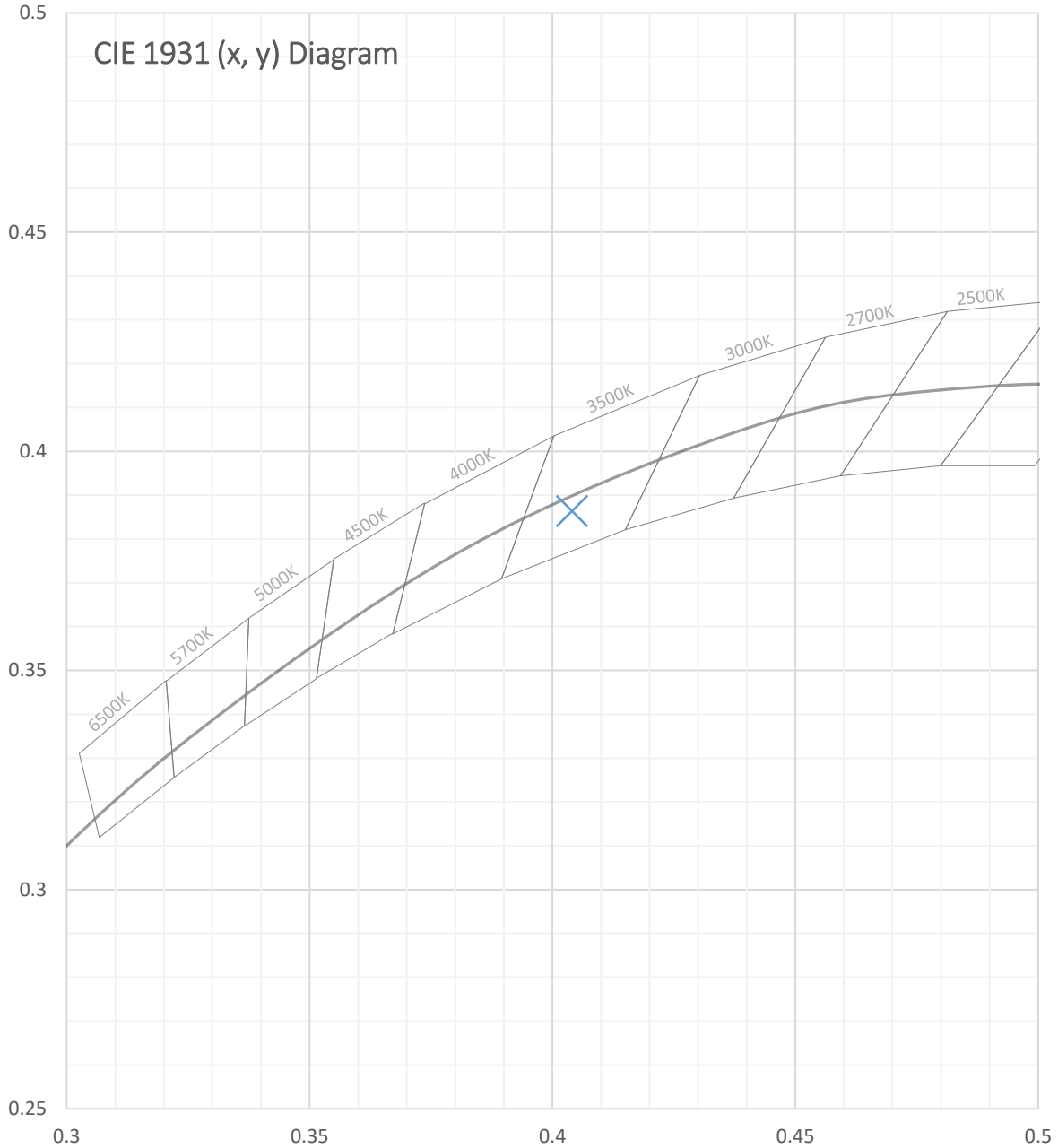

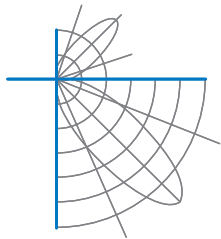

Test Report Number: LLIA001329-009B

Total Radiant Flux	10.98 W
Total Luminous Flux	3528.7 Lm
Chromaticity CIE 1931 (x, y)	(0.4040, 0.3864)
Chromaticity CIE 1976 (u', v')	(0.2367, 0.5093)
Correlated Color Temperature (CCT)	3492 K
Color Rendering Index (Ra)	84
R1	83
R2	91
R3	96
R4	82
R5	83
R6	88
R7	85
R8	65
R9	15
R10	79
R11	81
R12	67
R13	85
R14	98
TM-30: Rf	83
TM-30: Rg	96
Distance from Planckian Locus (Duv)	-0.0016
Scotopic/Photopic Ratio ‡	1.542

Electrical Data

Voltage	120.0 Vac
Current	0.2670 A
Power	31.65 W
Frequency	59.97 Hz
Power Factor	0.988
Current THD	6.6 %

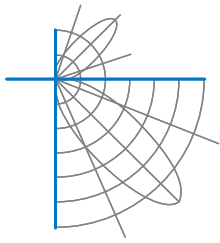

Test Report Number: LLIA001329-009B

Summary Spectral Power Distribution (wavelength - nm, spectral power - W/nm)

380	0.000483	480	0.015814	580	0.060432	680	0.018574
385	0.000517	485	0.016935	585	0.062431	685	0.016206
390	0.000639	490	0.019025	590	0.064254	690	0.014048
395	0.000792	495	0.022218	595	0.065201	695	0.012144
400	0.001024	500	0.026025	600	0.065624	700	0.010492
405	0.001234	505	0.029542	605	0.065114	705	0.009018
410	0.001461	510	0.032428	610	0.063752	710	0.007736
415	0.001805	515	0.034891	615	0.061775	715	0.006653
420	0.002511	520	0.036886	620	0.058980	720	0.005707
425	0.003921	525	0.038501	625	0.056032	725	0.004881
430	0.006627	530	0.040171	630	0.052799	730	0.004179
435	0.011451	535	0.041500	635	0.049319	735	0.003563
440	0.019722	540	0.043062	640	0.045664	740	0.003055
445	0.036376	545	0.044813	645	0.042038	745	0.002625
450	0.057613	550	0.046772	650	0.038283	750	0.002249
455	0.056016	555	0.048836	655	0.034511	755	0.001932
460	0.036955	560	0.050962	660	0.030999	760	0.001673
465	0.028632	565	0.053304	665	0.027377	765	0.001439
470	0.022986	570	0.055755	670	0.024141	770	0.001235
475	0.017241	575	0.058025	675	0.021251	775	0.001064
						780	0.000912

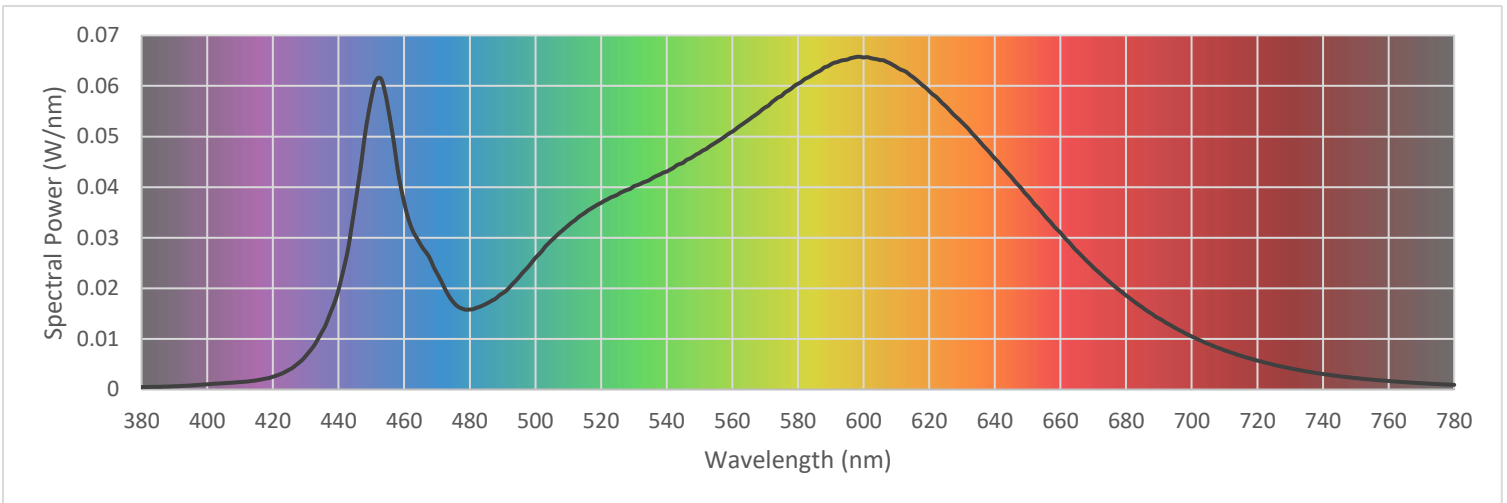

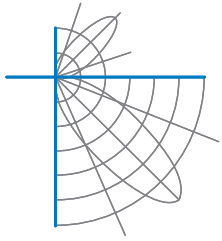

Test Report Number: LLIA001329-009B

IES TM-30 Details

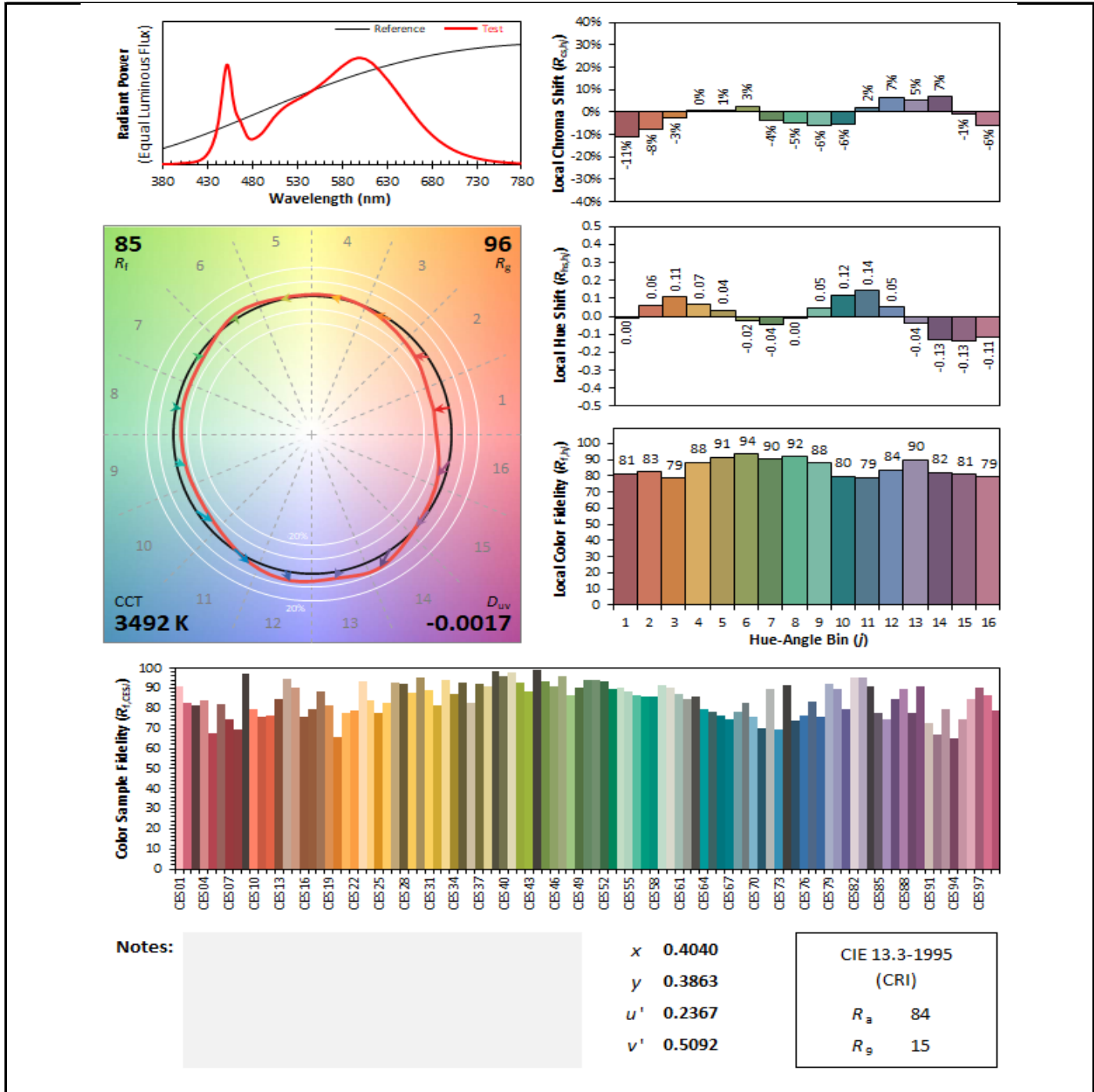

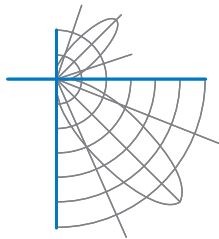

Test Report Number: LLIA001329-009B

Test Equipment Configuration: LightLab International Allentown 2m Integrating Sphere
Measurements acquired using a Labsphere CDS 2600 spectroradiometer
Testing was performed using 4π geometry

Test Temperature: 25.1 °C

Test Procedure: Tested in accordance with the applicable sections of:
LM-79-19, LM-78-07, LM-58-13, ANSI_ANSLG C78.377-2017, TM-30-18

Significance: The laboratory has not participated in the selection of samples to be tested.
All testing is performed on the understanding that the significance of the report is limited to the extent that the test sample is representative of production units.

Notes: The measurements and other derived quantities contained in this report are based on the absolute data as measured.

Prorating the performance of the sample for the use of other component combinations (such as lamp / LED / Ballast / driver), or for use in different environmental conditions than that tested, may produce erroneous results.

This report is free of erasures and corrections

This report may contain data that are not covered by the NVLAP accreditation. Quantities marked with ‡ are not covered.

This report must not be used by the customer to claim product certification, approval or endorsement by NVLAP, NIST, or any agency of the Federal Government.