

Report of Test

LLIA001329-011

Integrating Sphere Report

Catalog Number: PS5-A-HO-K35-80-4-XX-WTR-LOH-XXXV

Recessed mounted, extruded aluminum housing, formed white enamel aluminum LED tray, translucent white plastic enclosure.

144 white LEDs, two Osram PrevaLED Bars with 72 LEDs each.

One Osram Optotronic OTi 30/120-277/1A0 DIM-1 L G2LED driver labeled as 840mA

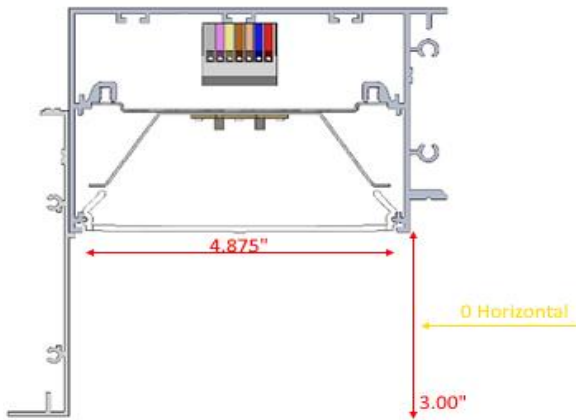

Performance Summary

Voltage	277.0 Vac
Current	0.1247 A
Power	32.04 W
Frequency	59.97 Hz
Power Factor	0.927
Current THD	14.5 %
Total Luminous Flux	3530.2 lm
Efficacy	110.2 lm/W
Chromaticity (x,y)	(0.4038, 0.3862)
(u',v')	(0.2366, 0.5091)
Duv	-0.0017
CCT	3496 K
CRI (Ra)	84
R9	16
TM-30: Rf	83
TM-30: Rg	96

Prepared For:

Precision Architectural Lighting
4830 Timber Creek Drive
Houston, TX 77017, USA

Test date: 10/20/2020
Report date: 10/14/2020

Signed: _____

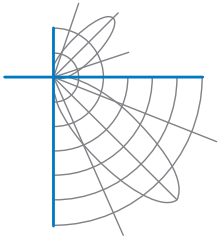

Test Report Number: LLIA001329-011

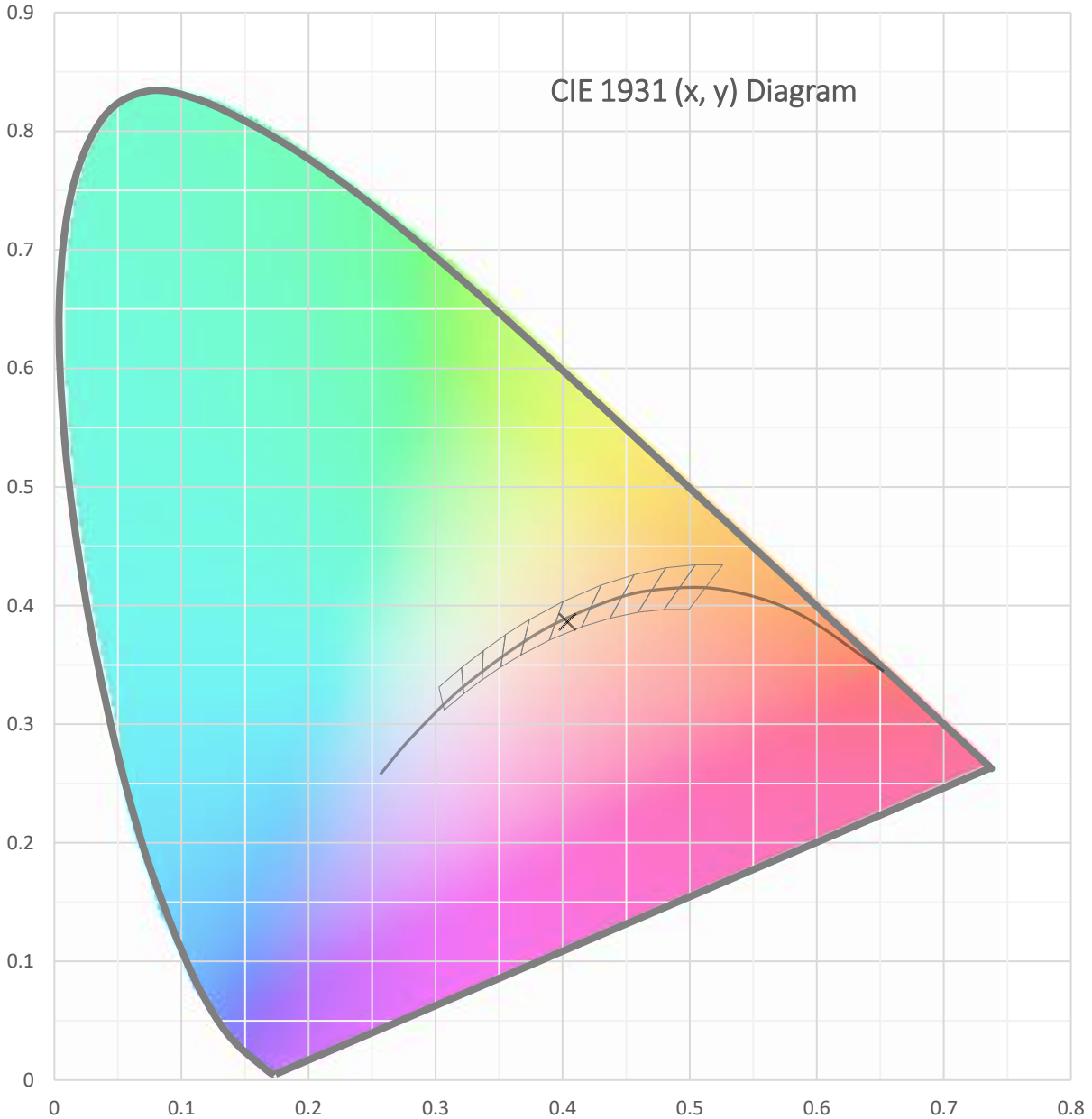

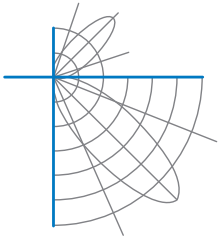

Test Report Number: LLIA001329-011

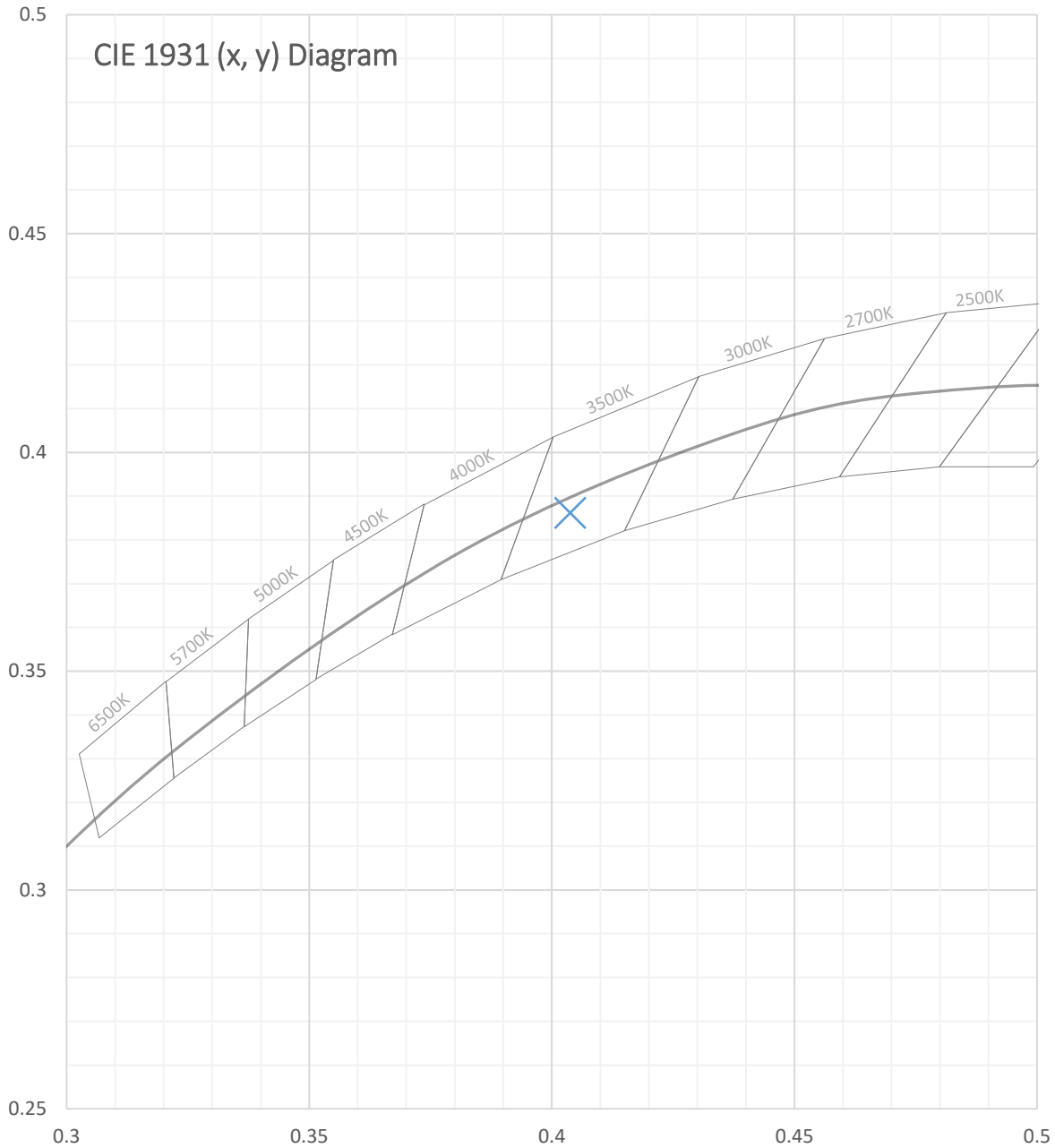

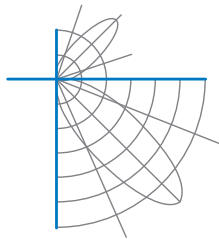

Test Report Number: LLIA001329-011

Total Radiant Flux	10.99 W
Total Luminous Flux	3530.2 Lm
Chromaticity CIE 1931 (x, y)	(0.4038, 0.3862)
Chromaticity CIE 1976 (u', v')	(0.2366, 0.5091)
Correlated Color Temperature (CCT)	3496 K
Color Rendering Index (Ra)	84
R1	83
R2	91
R3	96
R4	82
R5	83
R6	88
R7	85
R8	65
R9	16
R10	79
R11	81
R12	67
R13	85
R14	98
TM-30: Rf	83
TM-30: Rg	96
Distance from Planckian Locus (Duv)	-0.0017
Scotopic/Photopic Ratio ϕ	1.543

Electrical Data

Voltage	277.0 Vac
Current	0.1247 A
Power	32.04 W
Frequency	59.97 Hz
Power Factor	0.927
Current THD	14.5 %



Test Report Number: LLIA001329-011

Summary Spectral Power Distribution (wavelength - nm, spectral power - W/nm)

380	0.000488	480	0.015860	580	0.060466	680	0.018583
385	0.000523	485	0.016972	585	0.062414	685	0.016213
390	0.000647	490	0.019064	590	0.064276	690	0.014062
395	0.000794	495	0.022262	595	0.065199	695	0.012138
400	0.001023	500	0.026059	600	0.065664	700	0.010505
405	0.001243	505	0.029603	605	0.065129	705	0.009033
410	0.001481	510	0.032484	610	0.063747	710	0.007747
415	0.001814	515	0.034918	615	0.061773	715	0.006663
420	0.002522	520	0.036928	620	0.058976	720	0.005723
425	0.003944	525	0.038550	625	0.056026	725	0.004886
430	0.006660	530	0.040202	630	0.052767	730	0.004192
435	0.011516	535	0.041521	635	0.049293	735	0.003581
440	0.019792	540	0.043062	640	0.045678	740	0.003060
445	0.036509	545	0.044862	645	0.042021	745	0.002628
450	0.057789	550	0.046786	650	0.038275	750	0.002255
455	0.056139	555	0.048838	655	0.034531	755	0.001937
460	0.037035	560	0.050985	660	0.030998	760	0.001675
465	0.028711	565	0.053341	665	0.027372	765	0.001441
470	0.023048	570	0.055759	670	0.024151	770	0.001233
475	0.017278	575	0.058031	675	0.021244	775	0.001066
						780	0.000918

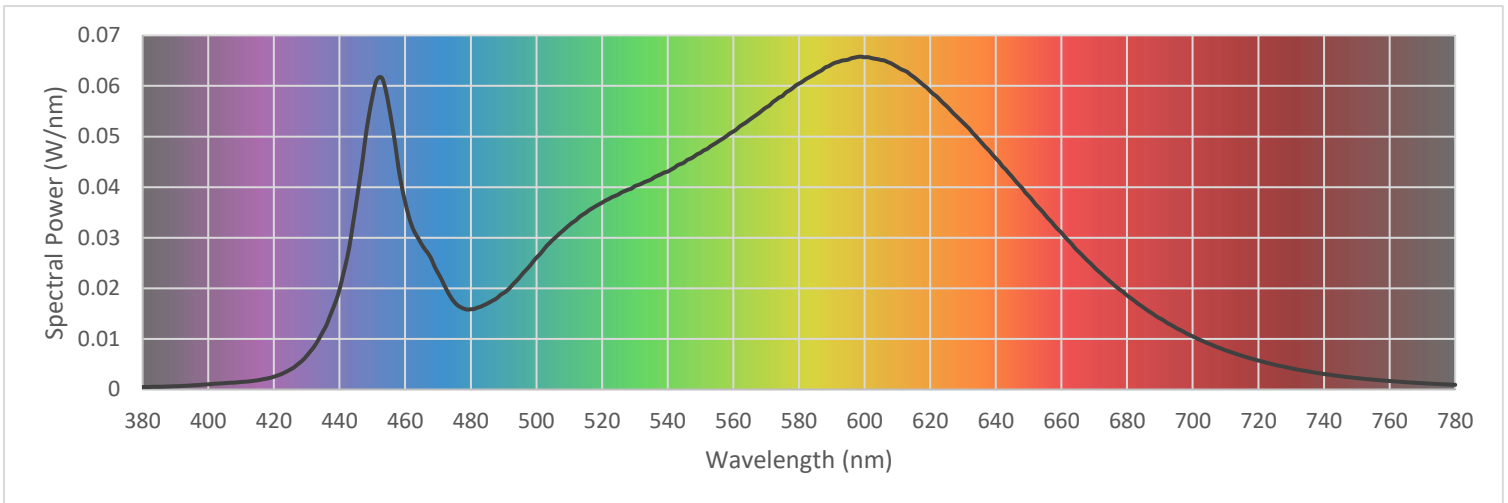

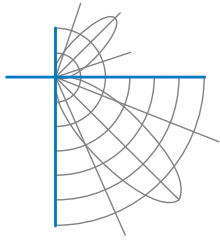

Test Report Number: LLIA001329-011

IES TM-30 Details

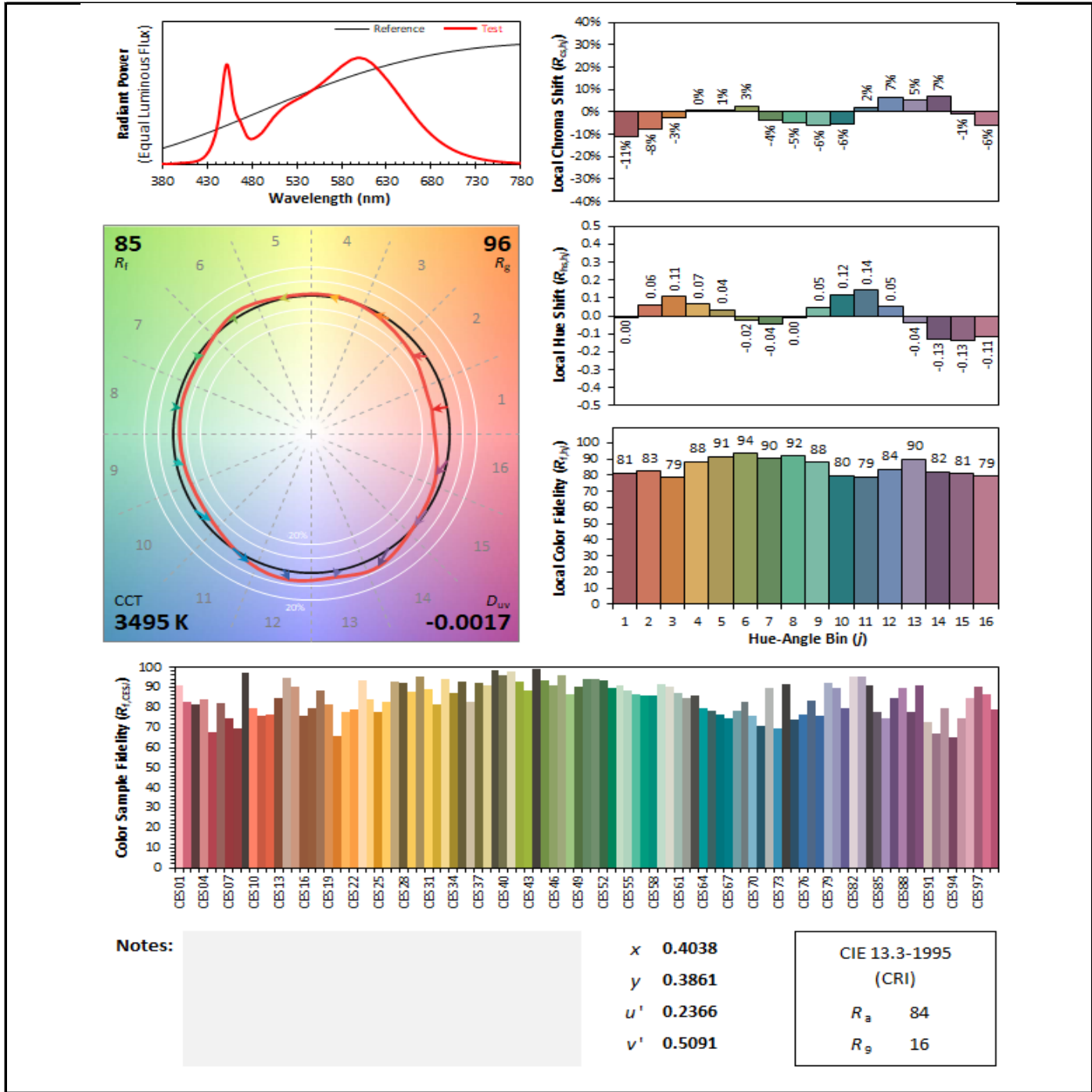



Test Report Number: LLIA001329-011

Test Equipment Configuration: LightLab International Allentown 2m Integrating Sphere
Measurements acquired using a Labsphere CDS 2600 spectroradiometer
Testing was performed using 4π geometry

Test Temperature: 24.9 °C

Test Procedure: Tested in accordance with the applicable sections of:
LM-79-19, LM-78-07, LM-58-13, ANSI_ANSLG C78.377-2017, TM-30-18

Significance: The laboratory has not participated in the selection of samples to be tested.
All testing is performed on the understanding that the significance of the report is limited to the extent that the test sample is representative of production units.

Notes: The measurements and other derived quantities contained in this report are based on the absolute data as measured.

Prorating the performance of the sample for the use of other component combinations (such as lamp / LED / Ballast / driver), or for use in different environmental conditions than that tested, may produce erroneous results.

This report is free of erasures and corrections

This report may contain data that are not covered by the NVLAP accreditation. Quantities marked with ‡ are not covered.

This report must not be used by the customer to claim product certification, approval or endorsement by NVLAP, NIST, or any agency of the Federal Government.