



Report of Test

LLIA001607-002A

Indoor Distribution Photometry Test Report

Catalog Number: ARR-ASYM-HO-K40-80-4-XX-120-DIM1

Recessed mounted, aluminum housing, steel end caps, aluminum reflector/LED holder and white painted ends, white plastic reflector sheet, open bottom.

One energized row of 184 white LEDs aimed up with one-piece diffuse plastic lens above LEDs

One Osram OTi30/120-277/1A0DIM-1LG2 LED driver labeled as 300mA

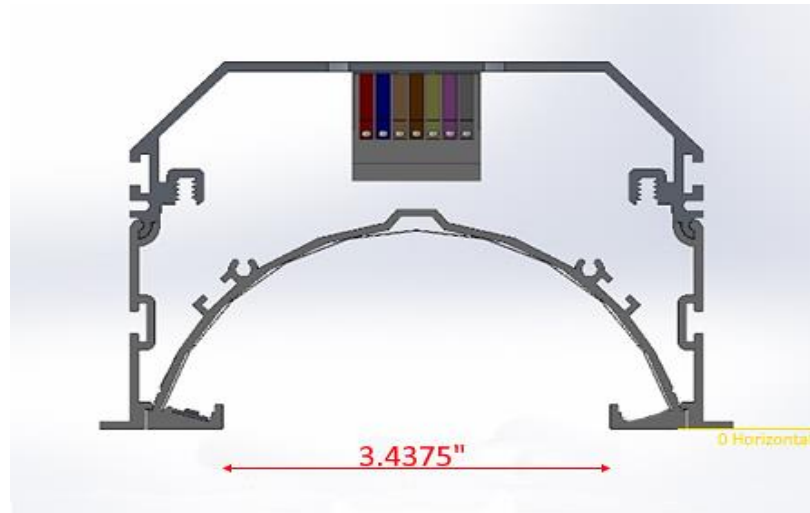

Prepared For:

Precision Architectural Lighting
4830 Timber Creek Drive
Houston, TX 77017, USA

Performance Summary

| | | | |
|---------------|-----------|----------------|------------------|
| Input Voltage | 120.0 Vac | Luminous Flux | 1194.3 Lumens |
| Input Current | 0.1032 A | Total Efficacy | 101.9 Lm/W |
| Input Power | 11.72 W | Downward Flux | 1194.3 Lumens |
| Frequency | 60.00 Hz | Downward Flux | 100.0 % of Total |
| Power Factor | 0.946 | | |
| Current THD | 15.6 % | | |

This test report was issued by LightLab International Allentown, LLC without alterations or erasures.

Test date: 12/16/2021

Report date: 12/16/2021

Signed: _____

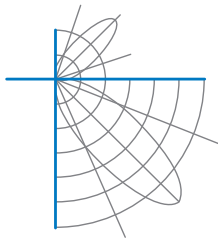

Report of Test
LLIA001607-002A

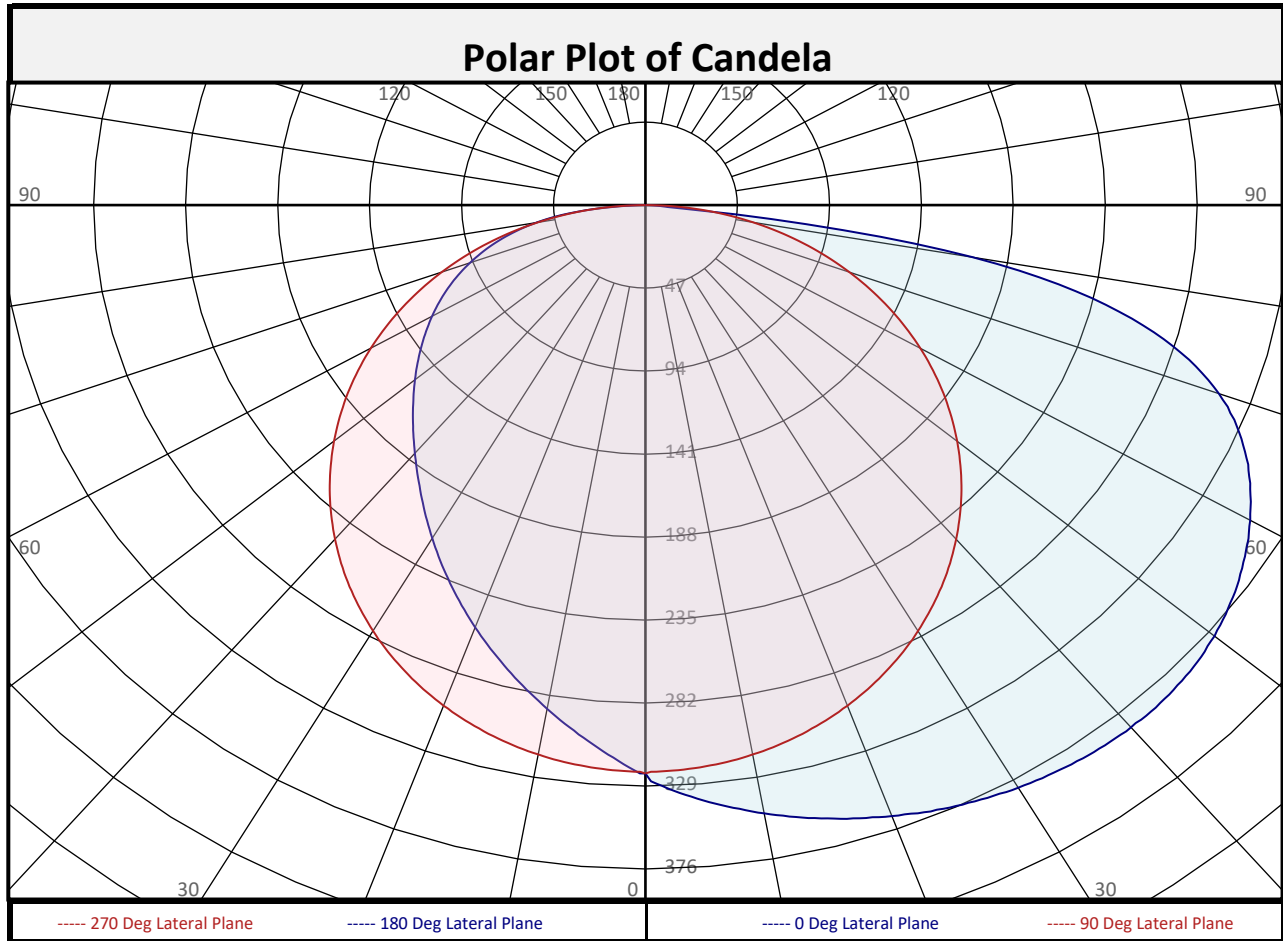

Zonal Flux Summary

| Zone (Deg Vert) | Flux (Lumens) | Percent of Total | Zone (Deg Vert) | Flux (Lumens) | Percent of Total | Zone (Deg Vert) | Flux (Lumens) | Percent of Total |
|-----------------|---------------|------------------|-----------------|---------------|------------------|-----------------|---------------|------------------|
| 0-10 | 30.5 | 2.6% | 90-100 | 0.0 | 0.0% | 0-20 | 118.7 | 9.9% |
| 10-20 | 88.2 | 7.4% | 100-110 | 0.0 | 0.0% | 0-30 | 256.0 | 21.4% |
| 20-30 | 137.3 | 11.5% | 110-120 | 0.0 | 0.0% | 0-40 | 429.5 | 36.0% |
| 30-40 | 173.5 | 14.5% | 120-130 | 0.0 | 0.0% | 0-60 | 822.2 | 68.8% |
| 40-50 | 194.4 | 16.3% | 130-140 | 0.0 | 0.0% | 0-80 | 1150 | 96.3% |
| 50-60 | 198.3 | 16.6% | 140-150 | 0.0 | 0.0% | 10-90 | 1164 | 97.5% |
| 60-70 | 183.7 | 15.4% | 150-160 | 0.0 | 0.0% | 20-50 | 505.2 | 42.3% |
| 70-80 | 144.3 | 12.1% | 160-170 | 0.0 | 0.0% | 40-90 | 764.8 | 64.0% |
| 80-90 | 44.1 | 3.7% | 170-180 | 0.0 | 0.0% | 60-90 | 372.1 | 31.2% |
| 0-90 | 1194 | 100.0% | 90-180 | 0.0 | 0.0% | 0-180 | 1194 | 100.0% |

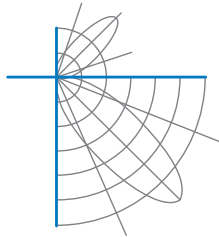

Report of Test

LLIA001607-002A

Luminous Intensity (Candela) Table

| | | Lateral (C-Plane) Angles | | | | | | | | |
|--|------|--------------------------|------|-----|------|-----|-------|-----|-------|-----|
| | | 0 | 22.5 | 45 | 67.5 | 90 | 112.5 | 135 | 157.5 | 180 |
| Vertical (Gamma) Angles - Data was acquired in 0.5° increments, 2.5° increments shown. | 0 | 322 | 322 | 322 | 322 | 322 | 322 | 322 | 322 | 322 |
| | 2.5 | 332 | 330 | 327 | 324 | 321 | 317 | 315 | 315 | 315 |
| | 5 | 338 | 336 | 331 | 326 | 320 | 313 | 309 | 307 | 307 |
| | 7.5 | 344 | 341 | 335 | 327 | 318 | 309 | 302 | 299 | 298 |
| | 10 | 350 | 346 | 338 | 328 | 316 | 304 | 295 | 291 | 290 |
| | 12.5 | 355 | 350 | 340 | 328 | 313 | 298 | 288 | 282 | 281 |
| | 15 | 360 | 354 | 342 | 327 | 310 | 293 | 280 | 274 | 272 |
| | 17.5 | 364 | 358 | 344 | 326 | 306 | 286 | 272 | 265 | 263 |
| | 20 | 368 | 361 | 345 | 324 | 302 | 279 | 264 | 257 | 254 |
| | 22.5 | 372 | 364 | 346 | 322 | 297 | 272 | 256 | 248 | 245 |
| | 25 | 375 | 367 | 346 | 319 | 291 | 264 | 247 | 239 | 236 |
| | 27.5 | 378 | 369 | 346 | 316 | 285 | 256 | 239 | 230 | 227 |
| | 30 | 381 | 370 | 345 | 312 | 278 | 248 | 229 | 220 | 218 |
| | 32.5 | 383 | 372 | 344 | 307 | 271 | 239 | 220 | 211 | 209 |
| | 35 | 384 | 372 | 342 | 303 | 264 | 230 | 210 | 202 | 200 |
| | 37.5 | 386 | 373 | 340 | 297 | 256 | 220 | 201 | 193 | 192 |
| | 40 | 386 | 372 | 337 | 291 | 247 | 210 | 191 | 184 | 183 |
| | 42.5 | 386 | 371 | 334 | 285 | 238 | 200 | 181 | 176 | 176 |
| | 45 | 384 | 370 | 331 | 278 | 228 | 190 | 172 | 168 | 168 |
| | 47.5 | 383 | 368 | 326 | 271 | 218 | 179 | 162 | 160 | 161 |
| 50 | 380 | 364 | 322 | 263 | 208 | 168 | 153 | 153 | 154 | |
| 52.5 | 375 | 360 | 317 | 255 | 197 | 157 | 144 | 146 | 147 | |
| 55 | 370 | 355 | 311 | 247 | 186 | 146 | 136 | 138 | 140 | |
| 57.5 | 364 | 348 | 304 | 238 | 174 | 134 | 128 | 131 | 133 | |
| 60 | 357 | 341 | 296 | 229 | 162 | 123 | 119 | 124 | 126 | |
| 62.5 | 348 | 333 | 288 | 219 | 150 | 112 | 111 | 117 | 119 | |
| 65 | 339 | 323 | 278 | 209 | 137 | 101 | 103 | 109 | 111 | |
| 67.5 | 327 | 312 | 268 | 198 | 124 | 91 | 95 | 101 | 104 | |
| 70 | 312 | 299 | 256 | 187 | 111 | 81 | 87 | 93 | 95 | |
| 72.5 | 291 | 281 | 243 | 175 | 97 | 71 | 79 | 85 | 87 | |
| 75 | 263 | 256 | 227 | 163 | 83 | 62 | 70 | 76 | 77 | |
| 77.5 | 225 | 223 | 206 | 149 | 70 | 53 | 61 | 66 | 67 | |
| 80 | 169 | 175 | 175 | 134 | 55 | 44 | 52 | 55 | 56 | |
| 82.5 | 83 | 98 | 127 | 115 | 41 | 35 | 41 | 43 | 43 | |
| 85 | 10 | 10 | 46 | 83 | 27 | 26 | 28 | 27 | 27 | |
| 87.5 | 4 | 4 | 4 | 15 | 13 | 14 | 11 | 10 | 10 | |
| 90 | 0 | 0 | 0 | 0 | 0 | 0 | 0 | 0 | 0 | |

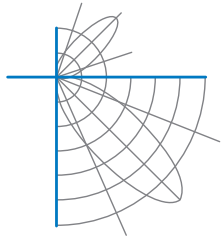

Report of Test

LLIA001607-002A

Luminous Intensity (Candela) Table

| | Lateral (C-Plane) Angles | | | | | | | | | |
|-------|--------------------------|------|----|------|----|-------|-----|-------|-----|---|
| | 0 | 22.5 | 45 | 67.5 | 90 | 112.5 | 135 | 157.5 | 180 | |
| 90 | 0 | 0 | 0 | 0 | 0 | 0 | 0 | 0 | 0 | 0 |
| 92.5 | 0 | 0 | 0 | 0 | 0 | 0 | 0 | 0 | 0 | 0 |
| 95 | 0 | 0 | 0 | 0 | 0 | 0 | 0 | 0 | 0 | 0 |
| 97.5 | 0 | 0 | 0 | 0 | 0 | 0 | 0 | 0 | 0 | 0 |
| 100 | 0 | 0 | 0 | 0 | 0 | 0 | 0 | 0 | 0 | 0 |
| 102.5 | 0 | 0 | 0 | 0 | 0 | 0 | 0 | 0 | 0 | 0 |
| 105 | 0 | 0 | 0 | 0 | 0 | 0 | 0 | 0 | 0 | 0 |
| 107.5 | 0 | 0 | 0 | 0 | 0 | 0 | 0 | 0 | 0 | 0 |
| 110 | 0 | 0 | 0 | 0 | 0 | 0 | 0 | 0 | 0 | 0 |
| 112.5 | 0 | 0 | 0 | 0 | 0 | 0 | 0 | 0 | 0 | 0 |
| 115 | 0 | 0 | 0 | 0 | 0 | 0 | 0 | 0 | 0 | 0 |
| 117.5 | 0 | 0 | 0 | 0 | 0 | 0 | 0 | 0 | 0 | 0 |
| 120 | 0 | 0 | 0 | 0 | 0 | 0 | 0 | 0 | 0 | 0 |
| 122.5 | 0 | 0 | 0 | 0 | 0 | 0 | 0 | 0 | 0 | 0 |
| 125 | 0 | 0 | 0 | 0 | 0 | 0 | 0 | 0 | 0 | 0 |
| 127.5 | 0 | 0 | 0 | 0 | 0 | 0 | 0 | 0 | 0 | 0 |
| 130 | 0 | 0 | 0 | 0 | 0 | 0 | 0 | 0 | 0 | 0 |
| 132.5 | 0 | 0 | 0 | 0 | 0 | 0 | 0 | 0 | 0 | 0 |
| 135 | 0 | 0 | 0 | 0 | 0 | 0 | 0 | 0 | 0 | 0 |
| 137.5 | 0 | 0 | 0 | 0 | 0 | 0 | 0 | 0 | 0 | 0 |
| 140 | 0 | 0 | 0 | 0 | 0 | 0 | 0 | 0 | 0 | 0 |
| 142.5 | 0 | 0 | 0 | 0 | 0 | 0 | 0 | 0 | 0 | 0 |
| 145 | 0 | 0 | 0 | 0 | 0 | 0 | 0 | 0 | 0 | 0 |
| 147.5 | 0 | 0 | 0 | 0 | 0 | 0 | 0 | 0 | 0 | 0 |
| 150 | 0 | 0 | 0 | 0 | 0 | 0 | 0 | 0 | 0 | 0 |
| 152.5 | 0 | 0 | 0 | 0 | 0 | 0 | 0 | 0 | 0 | 0 |
| 155 | 0 | 0 | 0 | 0 | 0 | 0 | 0 | 0 | 0 | 0 |
| 157.5 | 0 | 0 | 0 | 0 | 0 | 0 | 0 | 0 | 0 | 0 |
| 160 | 0 | 0 | 0 | 0 | 0 | 0 | 0 | 0 | 0 | 0 |
| 162.5 | 0 | 0 | 0 | 0 | 0 | 0 | 0 | 0 | 0 | 0 |
| 165 | 0 | 0 | 0 | 0 | 0 | 0 | 0 | 0 | 0 | 0 |
| 167.5 | 0 | 0 | 0 | 0 | 0 | 0 | 0 | 0 | 0 | 0 |
| 170 | 0 | 0 | 0 | 0 | 0 | 0 | 0 | 0 | 0 | 0 |
| 172.5 | 0 | 0 | 0 | 0 | 0 | 0 | 0 | 0 | 0 | 0 |
| 175 | 0 | 0 | 0 | 0 | 0 | 0 | 0 | 0 | 0 | 0 |
| 177.5 | 0 | 0 | 0 | 0 | 0 | 0 | 0 | 0 | 0 | 0 |
| 180 | 0 | 0 | 0 | 0 | 0 | 0 | 0 | 0 | 0 | 0 |

Vertical (Gamma) Angles - Data was acquired in 0.5° increments, 2.5° increments shown.



Report of Test

LLIA001607-002A

| Coefficients of Utilization/Room Utilization - Zonal Cavity Method | | | | | | | | | | | | | | | | | | | | | |
|--|-----|-----|-----|-----|-----|-----|-----|-----|-----|-----|-----|-----|-----|-----|-----|-----|-----|-----|----|----|---|
| Effective Floor Cavity Reflectance 0.20 | | | | | | | | | | | | | | | | | | | | | |
| RC | 80 | | | | 70 | | | | 50 | | | | 30 | | | | 10 | | | | 0 |
| RW | 70 | 50 | 30 | 10 | 70 | 50 | 30 | 10 | 50 | 30 | 10 | 50 | 30 | 10 | 50 | 30 | 10 | 50 | 30 | 10 | 0 |
| RCR | | | | | | | | | | | | | | | | | | | | | |
| 0 | 119 | 119 | 119 | 119 | 116 | 116 | 116 | 116 | 111 | 111 | 111 | 106 | 106 | 106 | 102 | 102 | 102 | 100 | | | |
| 1 | 107 | 101 | 96 | 91 | 104 | 99 | 94 | 90 | 94 | 91 | 87 | 90 | 87 | 84 | 87 | 84 | 82 | 79 | | | |
| 2 | 96 | 86 | 78 | 72 | 93 | 84 | 77 | 71 | 81 | 74 | 69 | 77 | 72 | 68 | 74 | 70 | 66 | 64 | | | |
| 3 | 86 | 74 | 65 | 58 | 84 | 73 | 64 | 57 | 70 | 62 | 56 | 67 | 61 | 55 | 64 | 59 | 54 | 52 | | | |
| 4 | 78 | 65 | 55 | 48 | 76 | 64 | 55 | 48 | 61 | 53 | 47 | 59 | 52 | 46 | 56 | 51 | 46 | 43 | | | |
| 5 | 72 | 58 | 48 | 41 | 70 | 57 | 47 | 40 | 54 | 46 | 40 | 52 | 45 | 39 | 50 | 44 | 39 | 37 | | | |
| 6 | 66 | 52 | 42 | 35 | 64 | 51 | 42 | 35 | 49 | 41 | 35 | 47 | 40 | 34 | 45 | 39 | 34 | 32 | | | |
| 7 | 61 | 47 | 37 | 31 | 59 | 46 | 37 | 31 | 44 | 36 | 30 | 43 | 35 | 30 | 41 | 35 | 30 | 28 | | | |
| 8 | 57 | 42 | 33 | 27 | 55 | 42 | 33 | 27 | 40 | 32 | 27 | 39 | 32 | 27 | 38 | 31 | 26 | 24 | | | |
| 9 | 53 | 39 | 30 | 24 | 51 | 38 | 30 | 24 | 37 | 29 | 24 | 36 | 29 | 24 | 35 | 28 | 24 | 22 | | | |
| 10 | 50 | 36 | 27 | 22 | 48 | 35 | 27 | 22 | 34 | 27 | 22 | 33 | 26 | 22 | 32 | 26 | 21 | 20 | | | |

For absolute test reports, RUs are expressed as a percentage of total lumen output. For relative test reports, CUs are expressed as a percentage of total lamp output. Calculations were based on published IES procedures, and are based on the zonal cavity method. Basic assumptions: 1) Room surfaces are lambertian reflectors. 2) Incident flux on each surface is uniformly distributed. 3) The room is spectrally neutral. When luminaires are not evenly distributed throughout the room, or do not exhibit lateral symmetry, CU values may differ from actual performance.

| Circle of Light Plot | | | | |
|----------------------|---------------------------|---|------------|--|
| Height(ft) | Illuminance at Nadir (fc) | Ground-level distance to half-of-nadir illuminance (ft) | | |
| | | 0-180 deg | 90-270 deg | |
| 6.0 | 8.9 | 8.42 | 7.72 | |
| 8.0 | 5.0 | 11.22 | 10.29 | |
| 10.0 | 3.2 | 14.03 | 12.87 | |
| 12.0 | 2.2 | 16.84 | 15.44 | |
| 14.0 | 1.6 | 19.64 | 18.02 | |
| 16.0 | 1.3 | 22.45 | 20.59 | |

| Spacing Criterion | |
|-------------------|-----|
| 0 deg: | 1.8 |
| 90 deg: | 1.3 |
| 180 deg: | 1.0 |
| 270 deg: | 1.3 |

| Average Luminance (cd/m ²) | | | |
|--|-------------|--------------|--------------|
| | 0 deg Plane | 45 deg Plane | 90 deg Plane |
| 0 | 3155 | 3155 | 3155 |
| 45 | 5330 | 4583 | 3165 |
| 55 | 6328 | 5312 | 3177 |
| 65 | 7860 | 6449 | 3179 |
| 75 | 9970 | 8610 | 3160 |
| 85 | 1128 | 5120 | 3050 |

| Beam and Field Angle | |
|----------------------|--------|
| 0-180 Degree Plane | |
| Beam Angle: | 116.1° |
| Field Angle: | 166.9° |
| 90-270 Degree Plane | |
| Beam Angle: | 106.7° |
| Field Angle: | 166.0° |

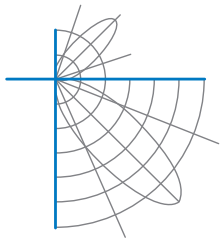

Report of Test

LLIA001607-002A

UGR Table - Corrected

Reflectances

| | | | | | | | | | | |
|----------------|----|----|----|----|----|----|----|----|----|----|
| Ceiling Cavity | 70 | 70 | 50 | 50 | 30 | 70 | 70 | 50 | 50 | 30 |
| Walls | 50 | 30 | 50 | 30 | 30 | 50 | 30 | 50 | 30 | 30 |
| Floor Cavity | 20 | 20 | 20 | 20 | 20 | 20 | 20 | 20 | 20 | 20 |

| Room Size | | UGR Viewed Crosswise | | | | | UGR Viewed Endwise | | | | |
|-----------|------|----------------------|------|------|------|------|--------------------|------|------|------|------|
| X=2H | Y=2H | 20.5 | 22.2 | 20.8 | 22.6 | 22.9 | 16.2 | 17.9 | 16.5 | 18.2 | 18.5 |
| | 3H | 23.6 | 25.2 | 24.0 | 25.5 | 25.9 | 18.4 | 20.0 | 18.7 | 20.3 | 20.7 |
| | 4H | 25.0 | 26.5 | 25.4 | 26.9 | 27.3 | 19.3 | 20.8 | 19.7 | 21.1 | 21.5 |
| | 6H | 26.1 | 27.5 | 26.5 | 27.9 | 28.3 | 20.0 | 21.5 | 20.4 | 21.8 | 22.2 |
| | 8H | 26.3 | 27.7 | 26.7 | 28.1 | 28.5 | 20.3 | 21.7 | 20.7 | 22.1 | 22.5 |
| | 12H | 26.3 | 27.7 | 26.8 | 28.0 | 28.5 | 20.5 | 21.8 | 20.9 | 22.2 | 22.6 |
| 4H | 2H | 21.2 | 22.7 | 21.6 | 23.1 | 23.4 | 17.6 | 19.1 | 18.0 | 19.5 | 19.8 |
| | 3H | 24.6 | 25.9 | 25.0 | 26.3 | 26.7 | 20.1 | 21.4 | 20.5 | 21.8 | 22.2 |
| | 4H | 26.2 | 27.4 | 26.6 | 27.8 | 28.2 | 21.2 | 22.4 | 21.6 | 22.8 | 23.2 |
| | 6H | 27.5 | 28.5 | 27.9 | 29.0 | 29.4 | 22.1 | 23.2 | 22.6 | 23.6 | 24.1 |
| | 8H | 27.8 | 28.7 | 28.2 | 29.2 | 29.6 | 22.5 | 23.5 | 23.0 | 23.9 | 24.4 |
| | 12H | 27.8 | 28.7 | 28.3 | 29.2 | 29.6 | 22.8 | 23.7 | 23.3 | 24.2 | 24.6 |
| 8H | 4H | 26.7 | 27.7 | 27.1 | 28.1 | 28.6 | 22.3 | 23.3 | 22.7 | 23.7 | 24.2 |
| | 6H | 28.1 | 29.0 | 28.6 | 29.5 | 29.9 | 23.5 | 24.4 | 24.0 | 24.9 | 25.3 |
| | 8H | 28.5 | 29.2 | 29.0 | 29.7 | 30.2 | 24.1 | 24.8 | 24.6 | 25.3 | 25.8 |
| | 12H | 28.5 | 29.2 | 29.0 | 29.7 | 30.2 | 24.5 | 25.2 | 25.0 | 25.7 | 26.2 |
| 12H | 4H | 26.8 | 27.7 | 27.2 | 28.1 | 28.6 | 22.5 | 23.4 | 23.0 | 23.9 | 24.3 |
| | 6H | 28.3 | 29.0 | 28.8 | 29.5 | 30.0 | 23.9 | 24.6 | 24.4 | 25.1 | 25.6 |
| | 8H | 28.7 | 29.3 | 29.2 | 29.8 | 30.4 | 24.5 | 25.2 | 25.0 | 25.7 | 26.2 |

Maximum UGR = 30.4

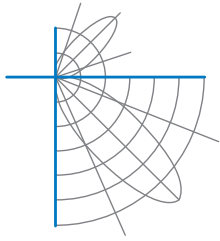

Report of Test
LLIA001607-002A

Iso-Illuminance Plot

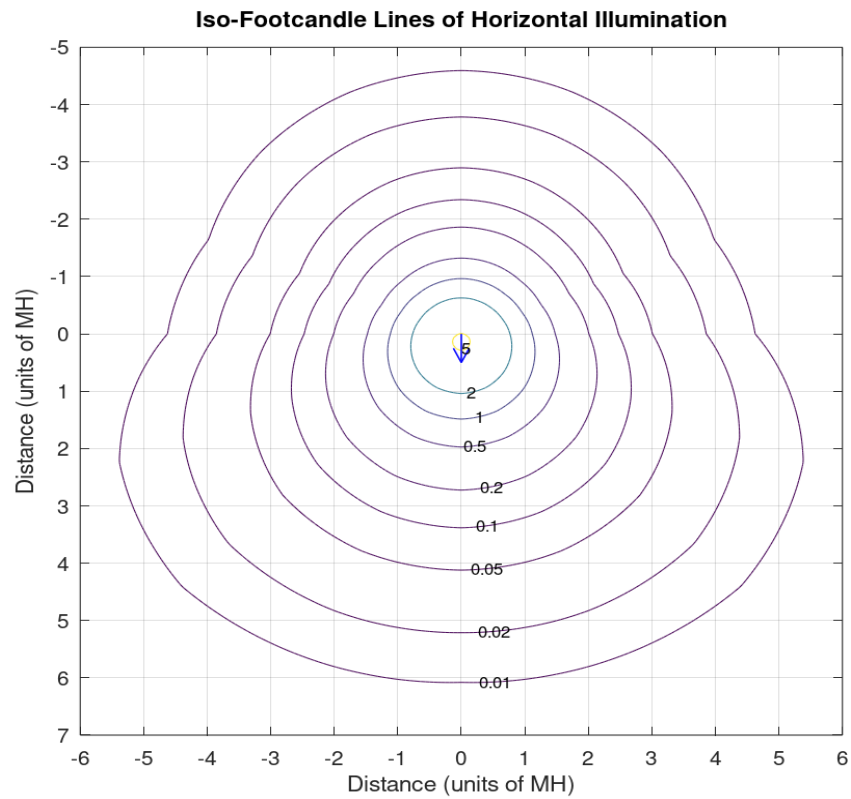

The isofootcandle values shown in the plot above are based on a mounting height of $h = 8.0$ feet. Grid values show multiples of mounting height. The isoilluminance contour lines are expressed in units of footcandles. The values expressed are based on the direct light from a single unit without the contribution of room reflections.

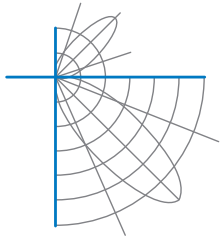

Report of Test
LLIA001607-002A

Additional Pictures of Test Subject



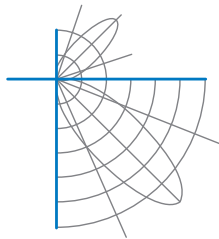

Report of Test

LLIA001607-002A

Test Distance 9.5 m
Ambient Temperature 24.9 °C

Notes

The laboratory has not participated in the selection of samples to be tested. All testing is performed on the understanding that the significance of the report is limited to the extent that the test sample is representative of production units.

Tested in accordance with the applicable sections of IES LM-79-19. Format of reports and angular increments based on IES LM-41-20 and LM-46-20.

The luminous intensity values, and other derived quantities, contained in this report are based on the absolute data, as measured.

Prorating the performance of the sample for the use of other component combinations (such as lamp / LED / Ballast / driver), or for use in different environmental conditions than that tested, may produce erroneous results.

This report is free of erasures and corrections.

Photometric intensity values are reported using the CIE C-Gamma coordinate system as defined in CIE publication number 121.

This report may contain data that are not covered by the NVLAP accreditation. Quantities marked with ‡ are not covered.

This report must not be used by the customer to claim product certification, approval or endorsement by NVLAP, NIST, or any agency of the Federal Government.

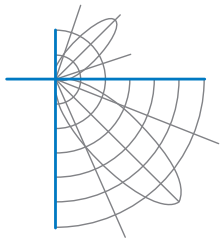

Report of Test

LLIA001607-002B

Integrating Sphere Report

Catalog Number: ARR-ASYM-HO-K40-80-4-XX-120-DIM1

Recessed mounted, aluminum housing, steel end caps, aluminum reflector/LED holder and white painted ends, white plastic reflector sheet, open bottom.

One energized row of 184 white LEDs aimed up with one-piece diffuse plastic lens above LEDs

One Osram OTi30/120-277/1A0DIM-1LG2 LED driver labeled as 300mA



Performance Summary

| | |
|---------------------|------------------|
| Voltage | 120.0 Vac |
| Current | 0.1036 A |
| Power | 11.72 W |
| Frequency | 59.99 Hz |
| Power Factor | 0.943 |
| Current THD | 15.6 % |
| Total Luminous Flux | 1202.9 lm |
| Efficacy | 102.6 lm/W |
| Chromaticity (x,y) | (0.3859, 0.3850) |
| (u',v') | (0.2254, 0.5060) |
| Duv | 0.0023 |
| CCT | 3916 K |
| CRI (Ra) | 83 |
| R9 | 8 |
| TM-30: Rf | 82 |
| TM-30: Rg | 94 |
| TM-30: Rcs,h1 | -12 |

Prepared For:

Precision Architectural Lighting
4830 Timber Creek Drive
Houston, TX 77017, USA

Test date: 12/14/2021

Report date: 12/16/2021

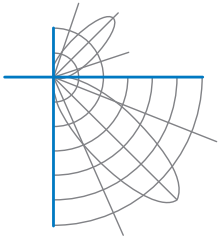

Test Report Number: LLIA001607-002B

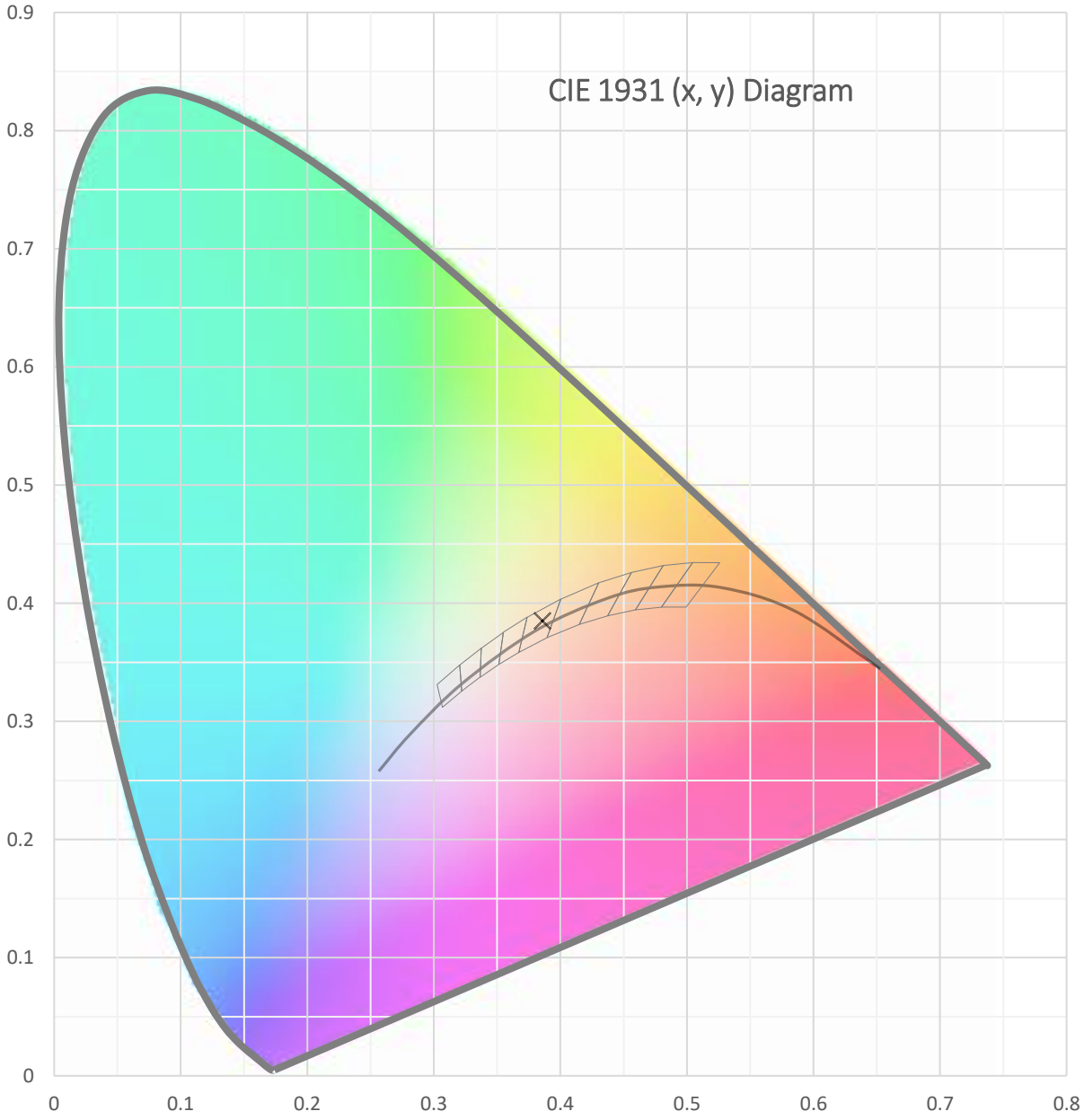

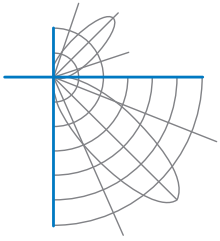

Test Report Number: LLIA001607-002B

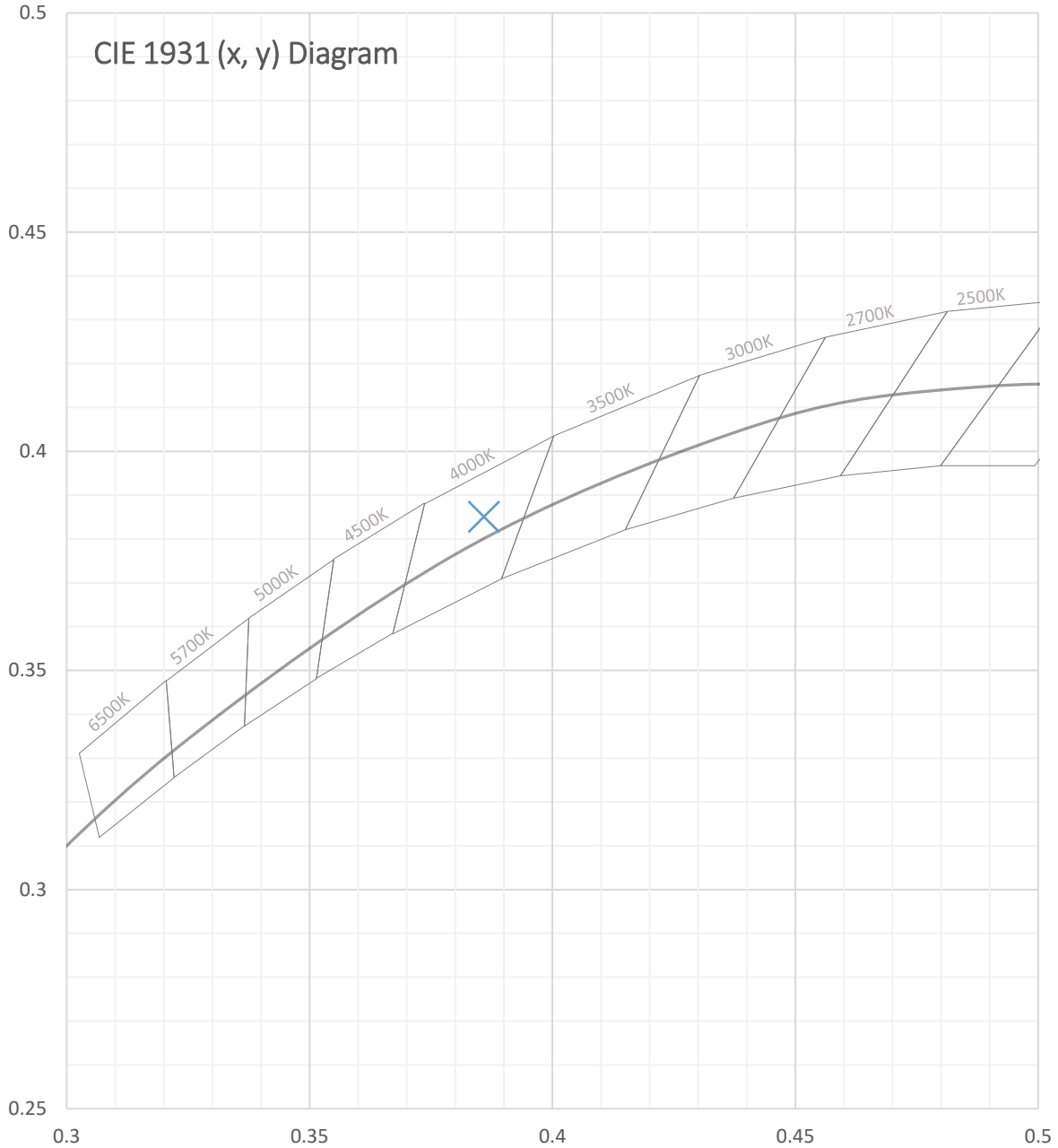



Test Report Number: LLIA001607-002B

| | |
|-------------------------------------|------------------|
| Total Radiant Flux | 3.633 W |
| Total Luminous Flux | 1202.9 Lm |
| Chromaticity CIE 1931 (x, y) | (0.3859, 0.3850) |
| Chromaticity CIE 1976 (u', v') | (0.2254, 0.5060) |
| Correlated Color Temperature (CCT) | 3916 K |
| Color Rendering Index (Ra) | 83 |
| R1 | 82 |
| R2 | 90 |
| R3 | 96 |
| R4 | 81 |
| R5 | 81 |
| R6 | 86 |
| R7 | 86 |
| R8 | 64 |
| R9 | 8 |
| R10 | 77 |
| R11 | 81 |
| R12 | 60 |
| R13 | 84 |
| R14 | 98 |
| TM-30: Rf | 82 |
| TM-30: Rg | 94 |
| TM-30: Rcs,h1 | -12 |
| Distance from Planckian Locus (Duv) | 0.0023 |
| Scotopic/Photopic Ratio ‡ | 1.677 |

Electrical Data

| | |
|--------------|-----------|
| Voltage | 120.0 Vac |
| Current | 0.1036 A |
| Power | 11.72 W |
| Frequency | 59.99 Hz |
| Power Factor | 0.943 |
| Current THD | 15.6 % |

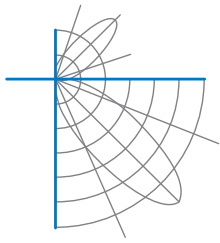

Test Report Number: LLIA001607-002B

Summary Spectral Power Distribution (wavelength - nm, spectral power - W/nm)

| | | | | | | | |
|-----|----------|-----|----------|-----|----------|-----|----------|
| 380 | 0.000142 | 480 | 0.006161 | 580 | 0.020142 | 680 | 0.004792 |
| 385 | 0.000149 | 485 | 0.006656 | 585 | 0.020590 | 685 | 0.004151 |
| 390 | 0.000170 | 490 | 0.007340 | 590 | 0.020949 | 690 | 0.003583 |
| 395 | 0.000218 | 495 | 0.008429 | 595 | 0.021072 | 695 | 0.003068 |
| 400 | 0.000285 | 500 | 0.009928 | 600 | 0.020917 | 700 | 0.002632 |
| 405 | 0.000360 | 505 | 0.011243 | 605 | 0.020575 | 705 | 0.002243 |
| 410 | 0.000450 | 510 | 0.012387 | 610 | 0.019981 | 710 | 0.001907 |
| 415 | 0.000578 | 515 | 0.013217 | 615 | 0.019167 | 715 | 0.001624 |
| 420 | 0.000811 | 520 | 0.013906 | 620 | 0.018224 | 720 | 0.001380 |
| 425 | 0.001223 | 525 | 0.014362 | 625 | 0.017143 | 725 | 0.001173 |
| 430 | 0.002011 | 530 | 0.014755 | 630 | 0.015965 | 730 | 0.001000 |
| 435 | 0.003465 | 535 | 0.015153 | 635 | 0.014731 | 735 | 0.000848 |
| 440 | 0.005920 | 540 | 0.015553 | 640 | 0.013417 | 740 | 0.000725 |
| 445 | 0.011459 | 545 | 0.016020 | 645 | 0.012131 | 745 | 0.000622 |
| 450 | 0.021428 | 550 | 0.016482 | 650 | 0.010848 | 750 | 0.000531 |
| 455 | 0.023127 | 555 | 0.017041 | 655 | 0.009607 | 755 | 0.000453 |
| 460 | 0.014565 | 560 | 0.017609 | 660 | 0.008483 | 760 | 0.000390 |
| 465 | 0.011415 | 565 | 0.018273 | 665 | 0.007394 | 765 | 0.000333 |
| 470 | 0.009760 | 570 | 0.018910 | 670 | 0.006406 | 770 | 0.000286 |
| 475 | 0.006982 | 575 | 0.019544 | 675 | 0.005534 | 775 | 0.000245 |
| | | | | | | 780 | 0.000212 |

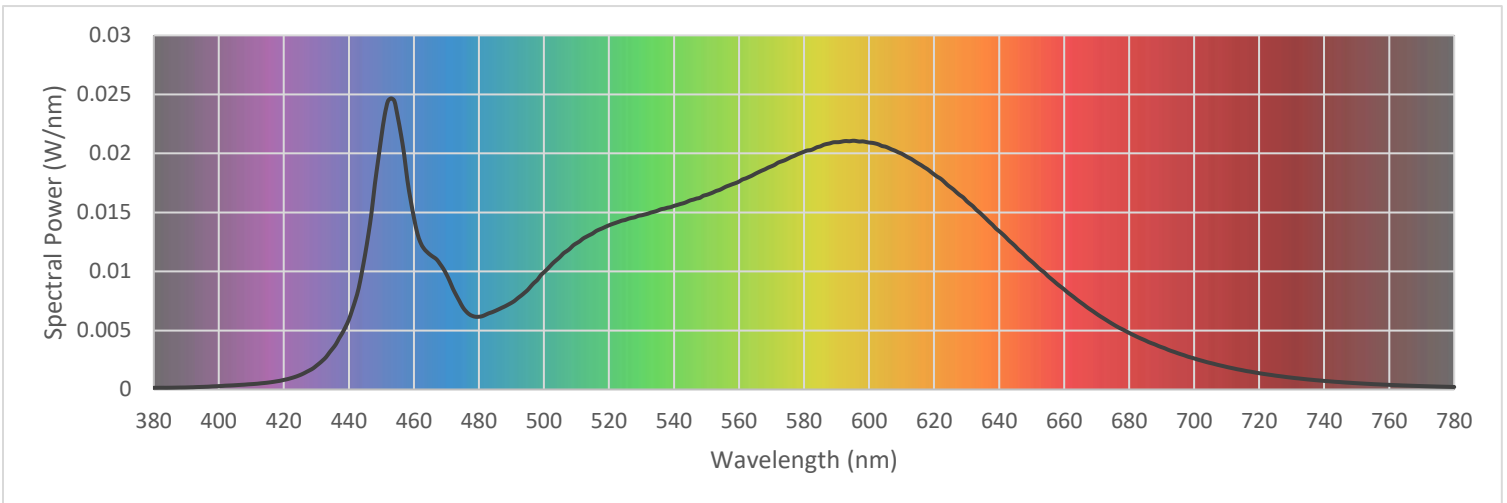

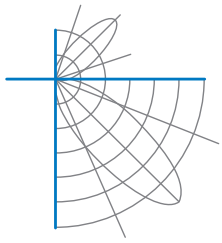

Test Report Number: LLIA001607-002B

IES TM-30 Details

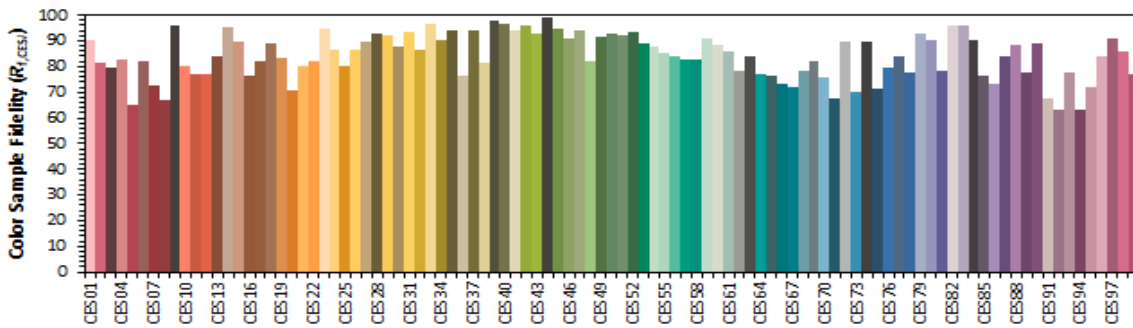
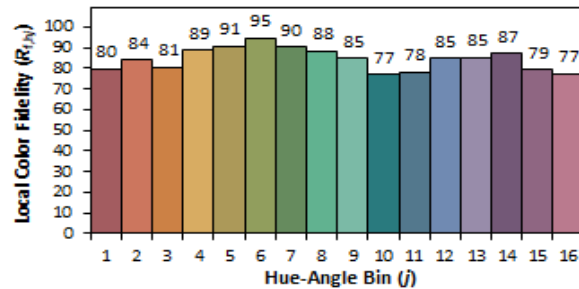
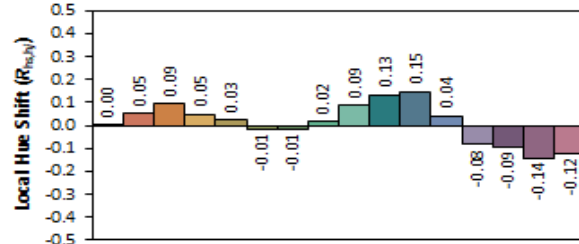
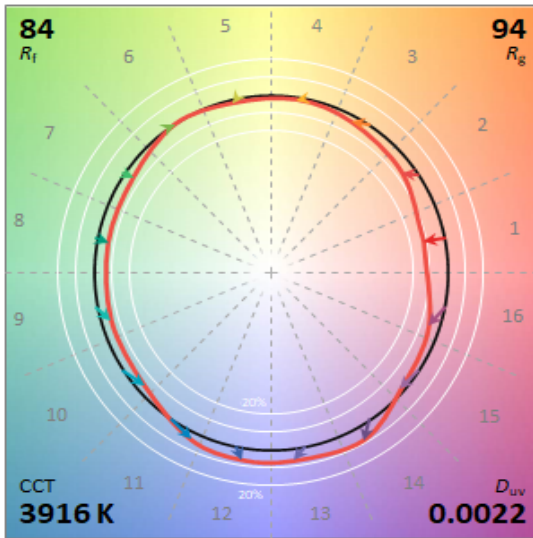
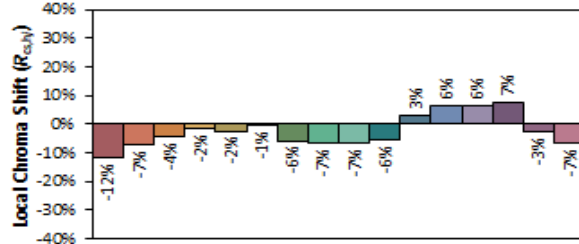
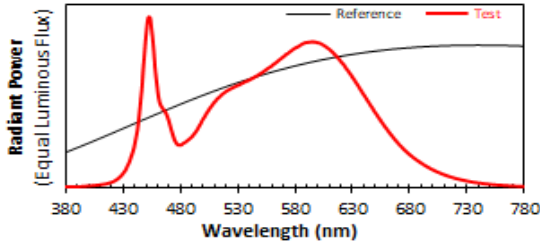

Notes:

x 0.3859
y 0.3850
u' 0.2254
v' 0.5060

| | |
|------------------------|----|
| CIE 13.3-1995 (CRI) | |
| R _a | 83 |
| R _s | 8 |

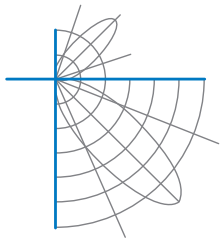

Test Report Number: LLIA001607-002B

Test Equipment Configuration: LightLab International Allentown 2m Integrating Sphere
Measurements acquired using a Labsphere CDS 2600 spectroradiometer
Testing was performed using 4π geometry

Test Temperature: 24.9 °C

Test Procedure: Tested in accordance with the applicable sections of:
LM-79-19, LM-78-20, LM-58-20, ANSI_ANSLG C78.377-2017, TM-30-20

Significance: The laboratory has not participated in the selection of samples to be tested.
All testing is performed on the understanding that the significance of the report is limited to the extent that the test sample is representative of production units.

Notes: The measurements and other derived quantities contained in this report are based on the absolute data as measured.

Prorating the performance of the sample for the use of other component combinations (such as lamp / LED / Ballast / driver), or for use in different environmental conditions than that tested, may produce erroneous results.

This report is free of erasures and corrections

This report may contain data that are not covered by the NVLAP accreditation. Quantities marked with ‡ are not covered.

This report must not be used by the customer to claim product certification, approval or endorsement by NVLAP, NIST, or any agency of the Federal Government.