

20 Mini Z Cove

3 Sided Pattern Coffer Submittal

Project Name _____ SO# _____

Fixture Type _____ PO# _____

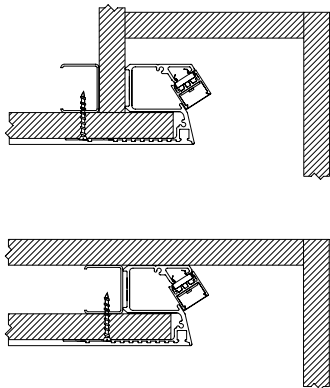
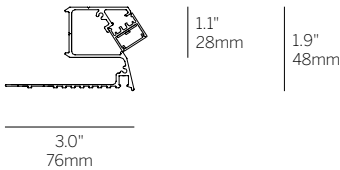

Gypsum Ceiling Mounting Options
2.5" minimum offset, 6" typical offset

Ordering Information

Model	Fixation	Pattern	Length	Power ²	CRI/ CCT ³	Driver ⁴	Lens	Finish
WG-20MZC	RPT							
WG-20MZC	RPT	PC ²	A A x B A x B x C A x B x A x B	L M	927 930 935 940	X S D010 L3DAE L3D0E DFPN	OD (std) SD	W (std) B G F

Luminaire

- Miniature continuous perimeter light with knife edge detail.
- Suitable for 5/8" drywall ceiling.
- Standard Opal Diffuser for even illumination and no LED appearance. Satin Diffuser for high efficiency and minimal LED appearance.
- Lengths and angles factory cut to exact field dimensions.
- Powder coat painted white - RAL 9010.
- 4' class 2 plenum rated feed cable standard.

Fixation

- RPT = Recessed Plaster Trim

Pattern

- S = Straight run¹
- PC = Standard patterns coffer 2, 3 or 4 sided with 90° corners²
- PR = Standard patterns raft 2, 3 or 4 sided with 90° corners²
- PZ = Non-standard patterns and/or corners other than 90°, consult factory²

Length

- A, B, C = specify inches to the nearest 0.25" (i.e. 72.25") For patterns specify each length (i.e. 2 sided: A x B = 72.25" x 48"; 3 sided: A x B x C; 4 sided: A x B x A x B)

Power³

- L = 3.2W/ft low power (24V)
- M = 6.4W/ft mid power (24V)

CCT/CRI⁴

- 90+ CRI minimum (Low/Mid)
- 927 = 2700K, (188/348 lm/ft)
 - 930 = 3000K (194/359 lm/ft)
 - 935 = 3500K, (198/366 lm/ft)
 - 940 = 4000K, (200/370 lm/ft)

Driver (remote)⁵

- S = Standard driver, 120-277V
- D010 = 10%, 0-10V dimming, 120-277V
- L3DAE = Lutron Hi-lume 1% EcoSystem, 120-277V
- L3D0E = Lutron Hi-lume Premier 0.1% EcoSystem, 120-277V
- DFPN = Lutron Forward Phase 1%, 120VAC

Lens

- OD = Satin opal diffuser (standard)
- SD = Satin clear diffuser (high efficiency)

Finish

- W = White, 20% gloss, RAL9010 (standard)
- B = Black, 20% gloss
- G = Gray, 20% gloss
- F = Custom finished trim, specify RAL

Emergency

- Contact factory for emergency lighting options

¹ Standard setup assumes the cove ends at a perpendicular wall and the LED board is set back from the end to minimize light on the perpendicular wall. See pattern specsheet for details.

² Wattage shown does not include power supplies/drivers.

³ Delivered lumens with satin opal diffuser shown.

⁴ Remote power supply required. See power supply specsheet.

Customer Approval

<input type="checkbox"/> Approved	Company _____
<input type="checkbox"/> Approved with corrections noted	Signature _____
<input type="checkbox"/> Revise and Resubmit	Print Name _____
	Date _____

Original Date Submitted _____

Mini Z Cove LED

Submittal - Pattern Coffer 3 Sided

Project Name _____ SO# _____

Fixture Type _____ PO# _____

Typical Non-Dim or 0-10V Dimming System Layout

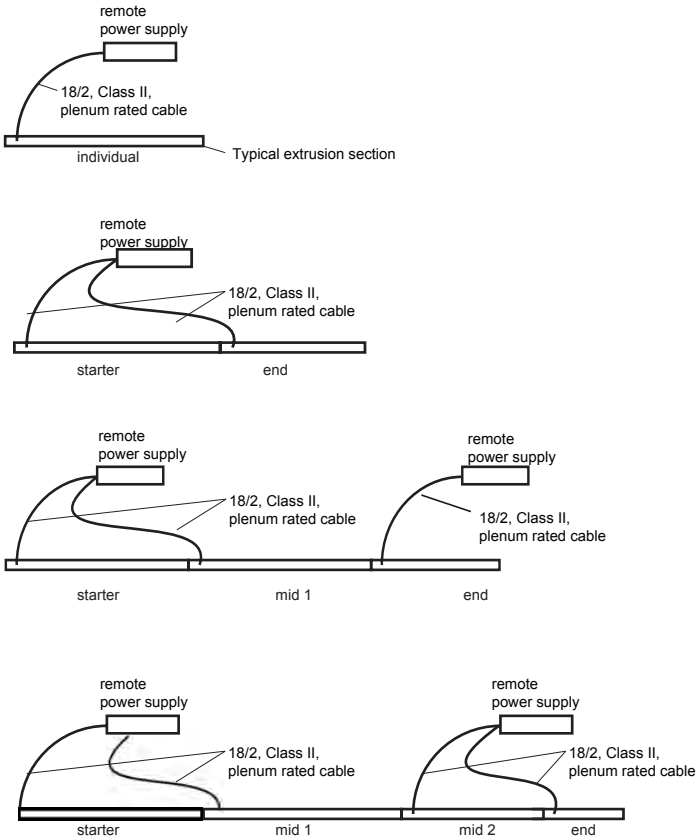

Non-Dimming and 0-10V Dimming Systems:

1. 96.25" maximum extrusion length.
2. 96W, 24V, constant voltage power supply (12ft max. length 6 W/ft, 24ft max. 3 W/ft per driver)

Typical Lutron Dimming System Layout

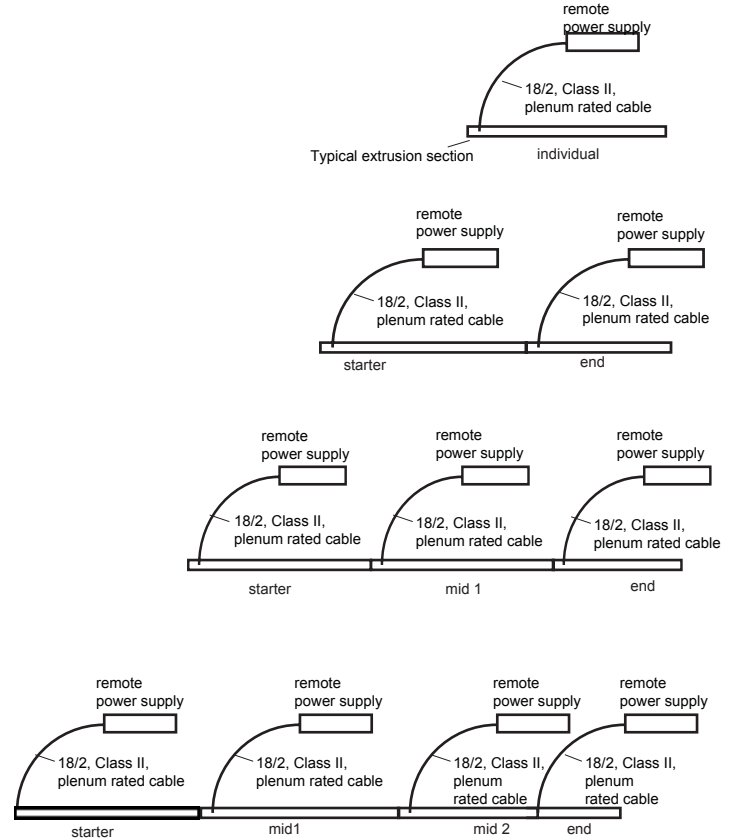

Lutron Dimming Systems:

1. 72" maximum extrusion length at 6 W/ft, 96" maximum extrusion length at 3 W/ft.
2. 40W, 24V, constant voltage power supply (5ft max. length 6 W/ft, 10ft max. 3 W/ft per driver)

General Notes for all system types:

1. End caps supplied in kits to be field installed at the end of each fixture.
2. Starters and Mid 1 extrusion sections are supplied with maximum lengths for long linear systems.
3. End extrusion sections have custom tailored length between 23.8" - 96.25" to obtain the overall system length.
4. When an End is calculated to be less than 23.8", a Mid 2 extrusion added to the system to split the length into manageable sizes.
5. Class II, plenum rated cable supplied hardwired to extrusion section, 4 ft length standard. Longer lengths available (specify when ordering)

Mini ZCoveLED

Submittal - Pattern Coffe 3 Sided

Project Name _____ SO# _____

Fixture Type _____ PO# _____

System	Qty.	A	B	C
1	_____	_____	_____	_____
2	_____	_____	_____	_____
3	_____	_____	_____	_____
4	_____	_____	_____	_____
5	_____	_____	_____	_____

Customer Approval		Company _____
<input type="checkbox"/> Approved		Signature _____
<input type="checkbox"/> Approved with corrections noted		Print Name _____
<input type="checkbox"/> Revise and Resubmit		Date _____

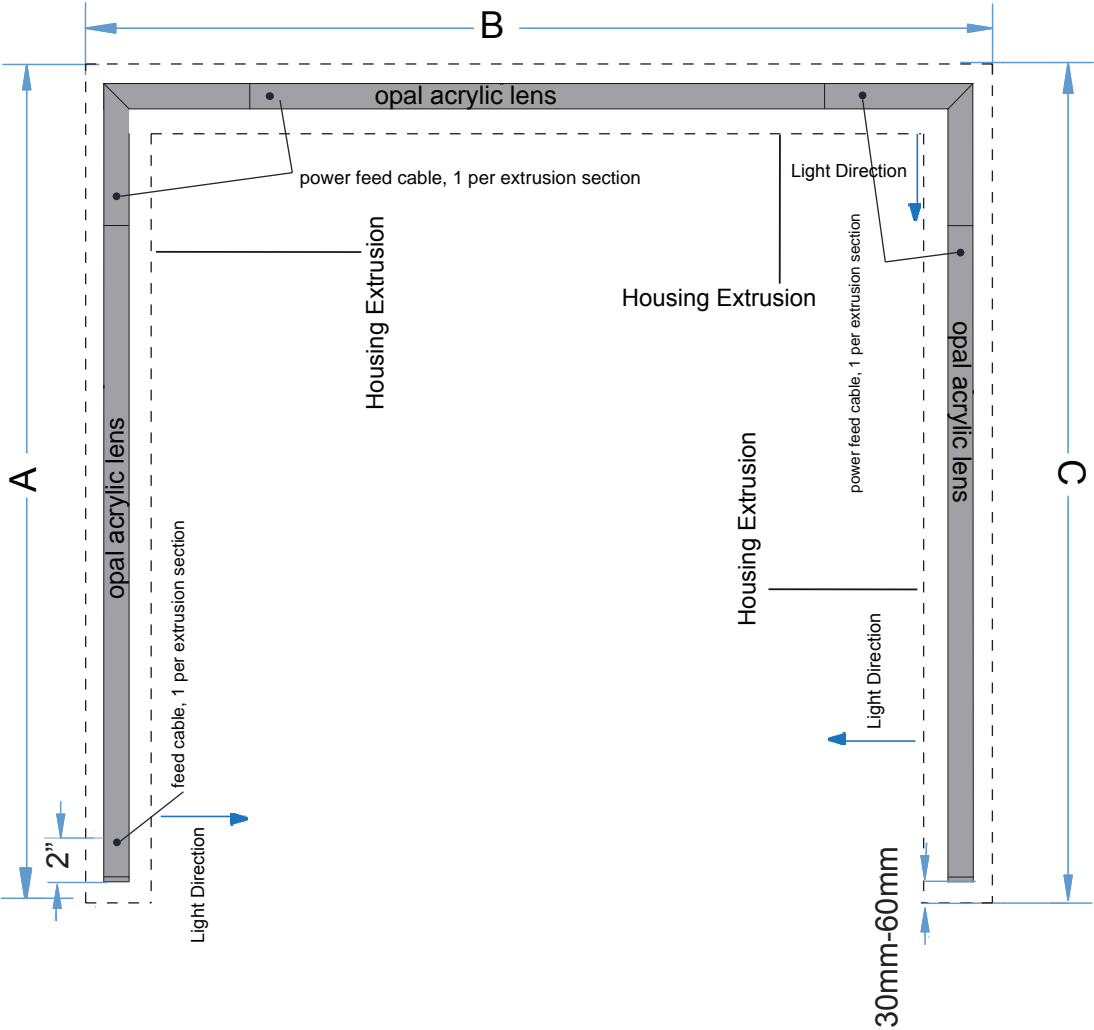

Note:
 Power feed is required for each extrusion section.
 Refer to page 2 for wiring diagrams and additional information to layout a typical linear system.