

GreenCobra™ LED Street Light

GC2 F-Series Specification Data Sheet

Luminaire Data

Weight 25 lbs [11.3 kg]
EPA 0.77 ft²

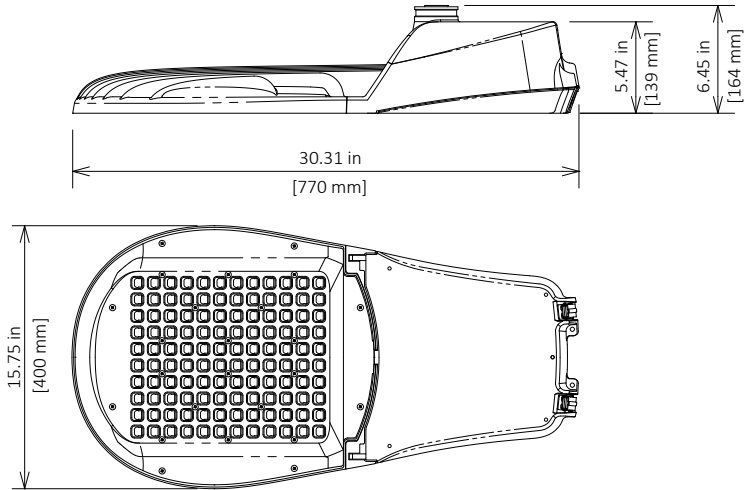

Ordering Information

Sample Catalog No. GC2 80F MV NW 2 GY FDC350

Product	No. & Type of LEDs	Voltage ¹	Color Temperature	Distribution	Finish ²	Drive Current Code ³		Options
GC2	90F 100F 120F	MV 120-277V HV 347-480V	WW 3000K NW 4000K CW 5000K	2 Type 2 3 Type 3	GY Gray DB Dark Bronze BK Black	350	350mA	HSS ⁵ House Side Shield (Factory Installed) FDC ⁶ Fixed Drive Current LPCR Less Photocontrol Receptacle PCR ⁷ ANSI 7-wire Photocontrol Receptacle PCR7-CR ⁷ Control Ready 7-wire Photocontrol Receptacle WL Utility Wattage Label
						530	530mA	
						700	700mA	
GC2	80F					700 1A ⁴	700mA 1A	

Notes:

- MV is DLC qualified. HV is DLC qualified on request, consult factory.
- Gray, Black and Dark Bronze standard, consult factory for other finishes.
- Specified drive current code is the factory set maximum drive current. Field adjustable current selector enables standard dimming to lower wattage drive currents only. Consult factory if wattage limits require a special drive current.
- 1A drive current only available with 80F.
- Flush mounted house side shield factory installed. Shield cuts light off at 1/2 mounting height behind luminaire.
- Non-field adjustable, fixed drive current.
- Control-ready wired at factory for wireless node dimming. Supplied at maximum drive current. If lower drive current is required, consult factory.
- Flush mounted house side shield. Shield cuts light off at 1/2 mounting height behind luminaire. Specify Model and Color.
- Specify Color (GY, DB, BK)
- Specify MV (120-277V) or HV (347V-480V)

Accessories*	
HSSGC ⁸	House Side Shield
SPB ⁹	Square Pole Horizontal Arm Bracket
RPB ⁹	Round Pole Horizontal Arm Bracket
PTB ⁹	Pole Top Tenon Horizontal Arm Bracket
WB ⁹	Wall Horizontal Arm Bracket
BSK	Bird Deterrent Spider Kit
LLPC ¹⁰	Long-Life Twist Lock Photocontrol
SC	Twist Lock Shorting Cap

*Unless specified for field installation, Shields and Shorting Caps are shipped installed. All other options are shipped separately.



Luminaire Specifications

Housing

Die cast aluminum housing with universal four-bolt slip fitter mounts to 1-1/4" to 2" (1-5/8" to 2-3/8" O.D.) diameter mast arm. Aluminum housing provides passive heat-sinking of the LEDs and has upper surfaces that shed precipitation. Mounting provisions meet 3G vibration per ANSI C136.31-2010 Normal Application, Bridge & Overpass. Mounting has leveling adjustment from + 10° to -5° in 2.5° steps and integral bubble level standard. All hardware is stainless steel material. Electrical components are accessed without tools and are mounted on removable power door with stainless steel latches. Standard rubber wildlife guard conforms to mast arm with no gaps.

Light Emitting Diodes

Hi-flux/Hi-power white LEDs produce a minimum of LEDs produce minimum 90% of initial intensity at 60,000 hours of life per IES recommended lumen maintenance life projection based on 6 times the duration of the collected LM-80 data. For details on IESNA Position on LED Product Lifetime Prediction, PS-10-18. LEDs have correlated color temperature of 3000K (WW), 4000K (NW), or 5000K (CW) and 70 CRI minimum. LEDs are ROHS compliant, 100% mercury and lead free.

Field Adjustability

LED lumen output can be changed in the field to adjust drive current for local conditions (not available with PCR7-CR option). The specified driver current will be the factory set output. Field adjustments can be made with the output selector included in the fixture. Field adjustable range shown in performance data table.

Quality Control

Every luminaire is performance tested before and after a 2-hour burn-in period. Assembled in the USA.

Optical Systems

Micro-lens optical systems produce IESNA Type 2 or Type 3 distributions and are fully sealed to maintain an IP66 rating. Luminaire produces 0% total lumens above 90° (BUG Rating, U=0). Optional house side shield cuts light off at 1/2 mounting height behind luminaire.

Electrical

Rated life of electrical components is 100,000 hours. Uses isolated power supply that is 1-10V dimmable. Power supply is wired with quick-disconnect terminals. Power supply features a minimum power factor of .90 and <20% Total Harmonic Distortion (THD). EMC meets or exceeds FCC CFR Part 15. Terminal block accommodates 6 to 14 gauge wire and is aligned for straight wire entry. Surge protection complies with IEEE/ANSI C62.41 Category C High, 20kV/10kA.

Controls

3-Wire photocontrol receptacle is standard. ANSI C136.41 7-wire (PCR7) photocontrol receptacle is available. All photocontrol receptacles have tool-less rotatable bases. Wireless control module is provided by others.

Finish

Housing receives a fade and abrasion resistant polyester powder coat finish. Finish tested to withstand 3000 hours in salt spray exposure per ASTM B117. Finish tested 500 hours in UV exposure per ASTM G154 and meets ASTM D523 gloss retention.

Listings/Ratings/Labels

Luminaires are UL listed for use in wet locations. Luminaires are UL listed for use in wet locations in the United States and Canada. Design Lights Consortium™ qualified product. Consult DLC QPL for Standard and Premium Classification Listings. All electronic components inside of the luminaire are NRTL damp location rated per ANSI 136.37-2011 Ingress Protection standard. International Dark Sky Association listed. Luminaire is qualified to operate at ambient temperatures of -40°C to 40°C. Assembled in the U.S.A.

Photometry

Luminaires photometrics are tested by certified independent testing laboratories in accordance with IES LM-79 testing procedures. IES files for all CCTs are available at leotek.com.

Vandal Resistance

Housing and optics rated to IK10

Warranty

10-year limited warranty is standard on luminaire and components. See Leotek.com for warranty details.

Color Specifications

Order Code	Color	RAL #	Pantone Equivalent
GY	Gray	7040	429C
BK	Black	9004	426C
DB	Dark Bronze	6022	BLACK 2C

TM21 Lumen Maintenance per IES TM21-11 Calculation

Model Number	60,000 Hours*	80,000 Hours	100,000 Hours
All GC2F	>96%	>95%	>93%

*Calculation based on IES position statement on Lumen Maintenance Life Projections

Performance Data

All data nominal. IES files for all CCTs are available at leotek.com.

No. of LEDs & Type	Drive Current (mA)	System Wattage (W)	Delivered Lumens (Lm) ¹	Efficacy (Lm/W)	Type 2	Type 3
					BUG Rating	BUG Rating
80F	700	180	17700	98	B3 U0 G3	B3 U0 G3
	1000	277	24500	88	B4 U0 G4	B4 U0 G4
90F	350	95	10800	114	B2 U0 G2	B3 U0 G3
	530	150	16050	107	B3 U0 G3	B3 U0 G3
	700	195	19800	102	B3 U0 G3	B3 U0 G3
100F	350	105	11700	111	B3 U0 G3	B3 U0 G3
	530	167	17400	104	B3 U0 G3	B3 U0 G3
	700	220	22000	100	B3 U0 G3	B3 U0 G3
120F	350	130	14600	112	B3 U0 G3	B3 U0 G3
	530	200	20800	104	B3 U0 G3	B3 U0 G3
	700	260	26400	102	B4 U0 G4	B4 U0 G4

Notes:

1 All data nominal lumens for 4000K (NW) and 5000K (CW). For 3000K (WW) apply a LLF of 0.93. Normal tolerance ± 10% due to factors including distribution type, LED bin variance, and ambient temperatures.