

WIRE ACCESS HOLE

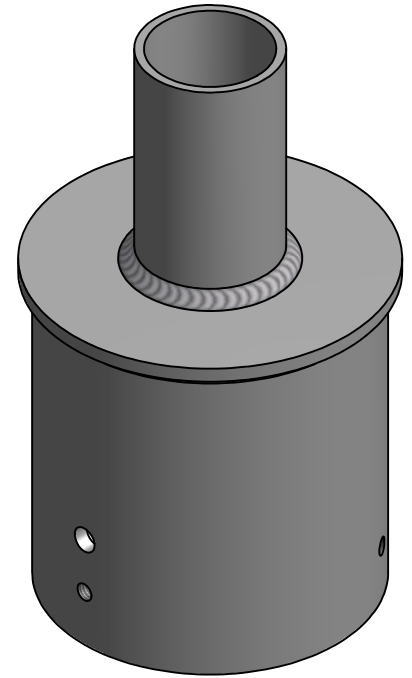

PTR-5RD-T2-STD

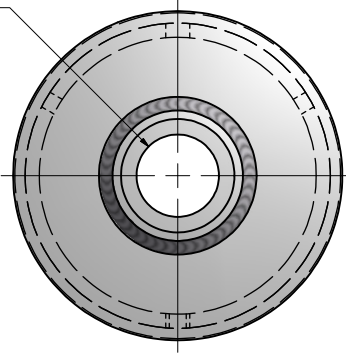
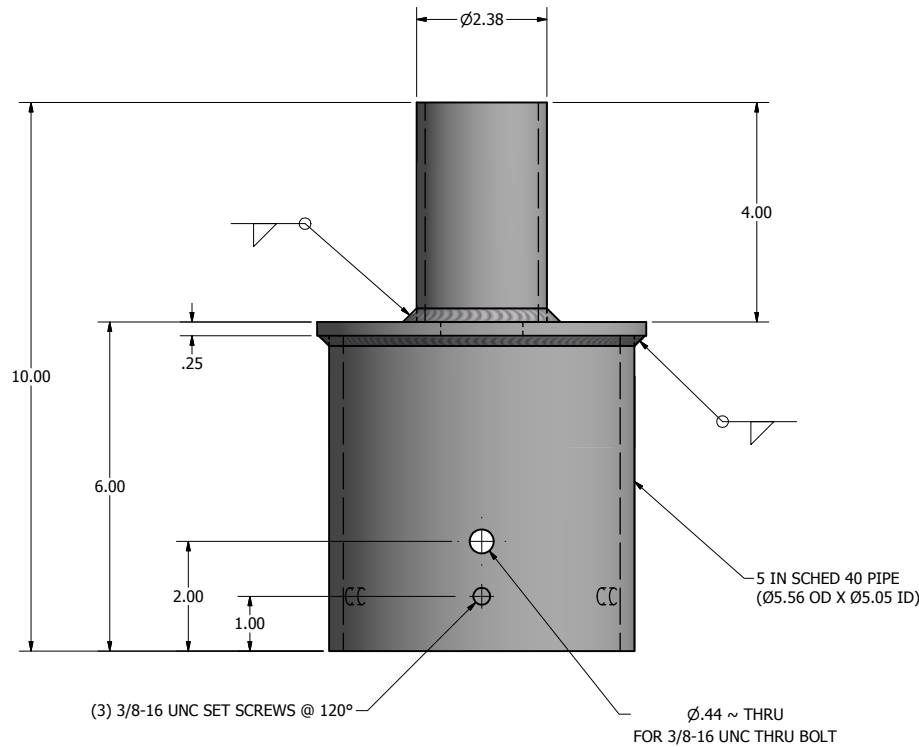

- TENON OPTIONS**
 T2- Ø2.38 OD X 4.00 LG
 T3- Ø3.00 OD X 5.00 LG
 T4- Ø4.00 OD X 6.00 LG

NOTE: OTHER TENON SIZES AVAILABLE UPON REQUEST,
 CONTACT FACTORY FOR ADDITIONAL SIZES.

FINISH: BRACKET SHALL BE POLYESTER POWDER COAT FINISH IN A STANDARD COLOR.

<p>HAND HOLE</p>	DRAWN: M. HARVALA	2/10/2015
	CHECKED:	
	REVISION:	DATE:
	APPROVED:	
	QUOTE:	
	S.O.#	
REF:	SCALE: NONE	

UNITED LIGHTING STANDARDS
A DWH COMPANY

23171 Groesbeck Hwy.
 Warren, MI 48089
 P: (586) 774-5650 | F: (586) 774-5706
www.unitedlightingstandards.com

SOME GEOGRAPHICAL AREAS HAVE SPECIAL WIND CONDITIONS THAT CAN CREATE WIND INDUCED VIBRATIONS CAUSING A FATIGUE PROBLEM. NO METHOD HAS YET BEEN FOUND FOR PREDICTING DESTRUCTIVE LIGHTING POLE VIBRATION. THESE CONDITIONS ARE UNIQUE AND CANNOT BE GUARANTEED AGAINST, AND ARE THE RESPONSIBILITY OF A LOCAL SITE ENGINEER.		
TITLE:		
CATALOG:		
DWG NO:	PTR-5RD-T2-STD	SIZE: C SHEET 1 OF 1