

TOP MOUNTED CROSS ARM			
CATALOG #	FIXTURE QTY.	EPA (SQ. FT.)	WEIGHT (LBS.)
CRT-02	2	1.6	87

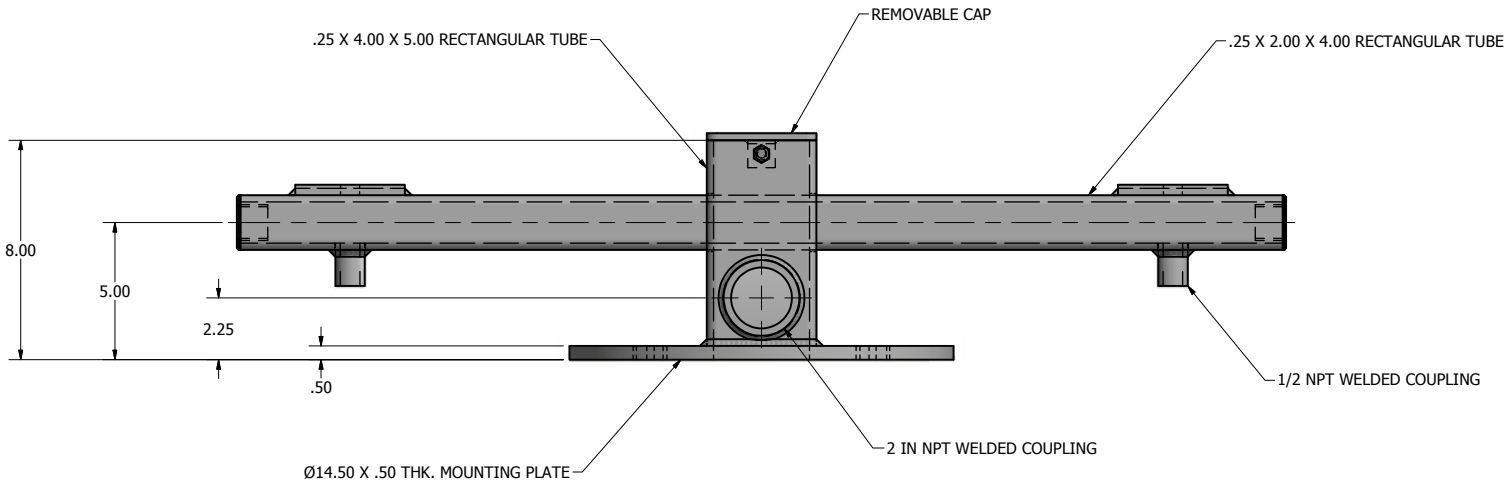

FINISH: TOP MOUNTED CROSS ARM BRACKET TO BE FINISHED TO MATCH POLE.

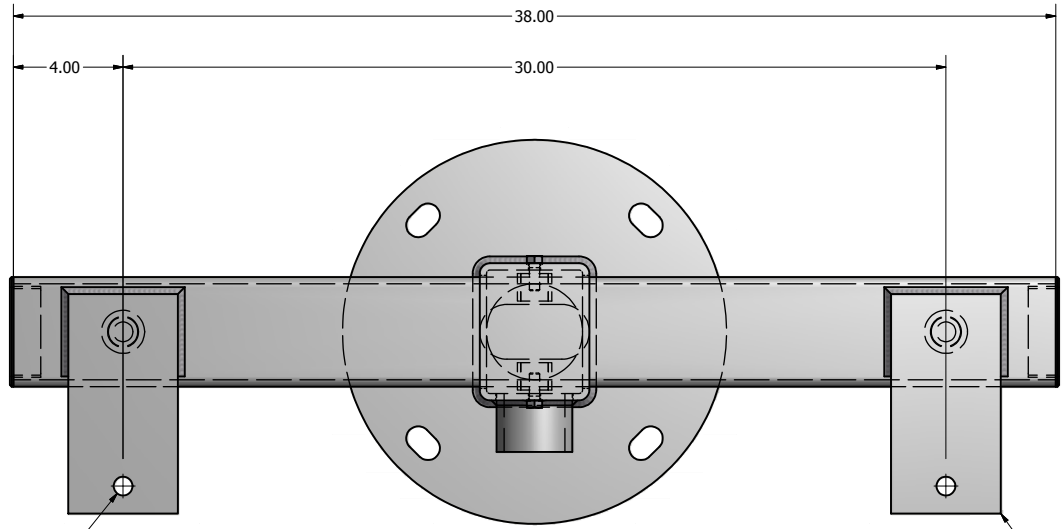
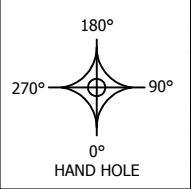

DRAWN: M. HARVALA	2/9/2015
CHECKED:	
REVISION:	DATE:
APPROVED:	
QUOTE:	
S.O.#	
REF:	SCALE: NONE

UNITED LIGHTING STANDARDS
 A DWH COMPANY

23171 Groesbeck Hwy.
 Warren, MI 48089
 P: (586) 774-5650 | F: (586) 774-5706
www.unitedlightingstandards.com

SOME GEOGRAPHICAL AREAS HAVE SPECIAL WIND CONDITIONS THAT CAN CREATE WIND INDUCED VIBRATIONS CAUSING A FATIGUE PROBLEM. NO METHOD HAS YET BEEN FOUND FOR PREDICTING DESTRUCTIVE LIGHTING POLE VIBRATION. THESE CONDITIONS ARE UNIQUE AND CANNOT BE GUARANTEED AGAINST, AND ARE THE RESPONSIBILITY OF A LOCAL SITE ENGINEER.		
TITLE:		
CATALOG:		
DWG NO: CRT-02	SIZE: C	SHEET 1 OF 1