

POST TOP BULLHORN BRACKET		
CATALOG #	DESCRIPTION	EPA (SQ. FT.)
PTB-4	4 FLOOD LIGHTS AT 90 DEG.	1.6

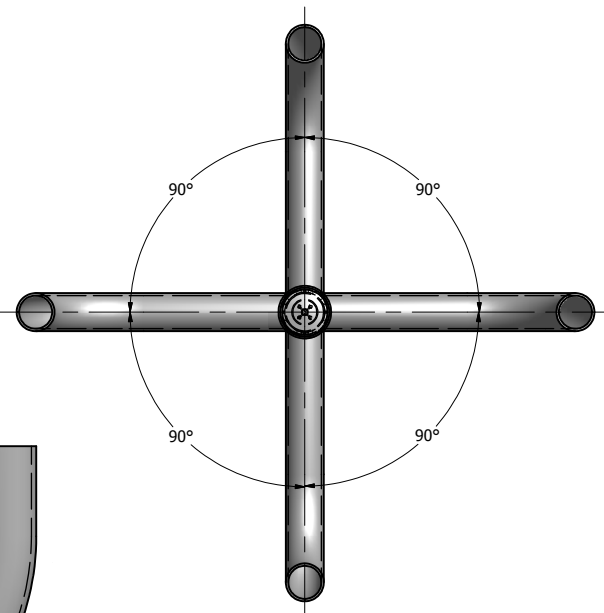
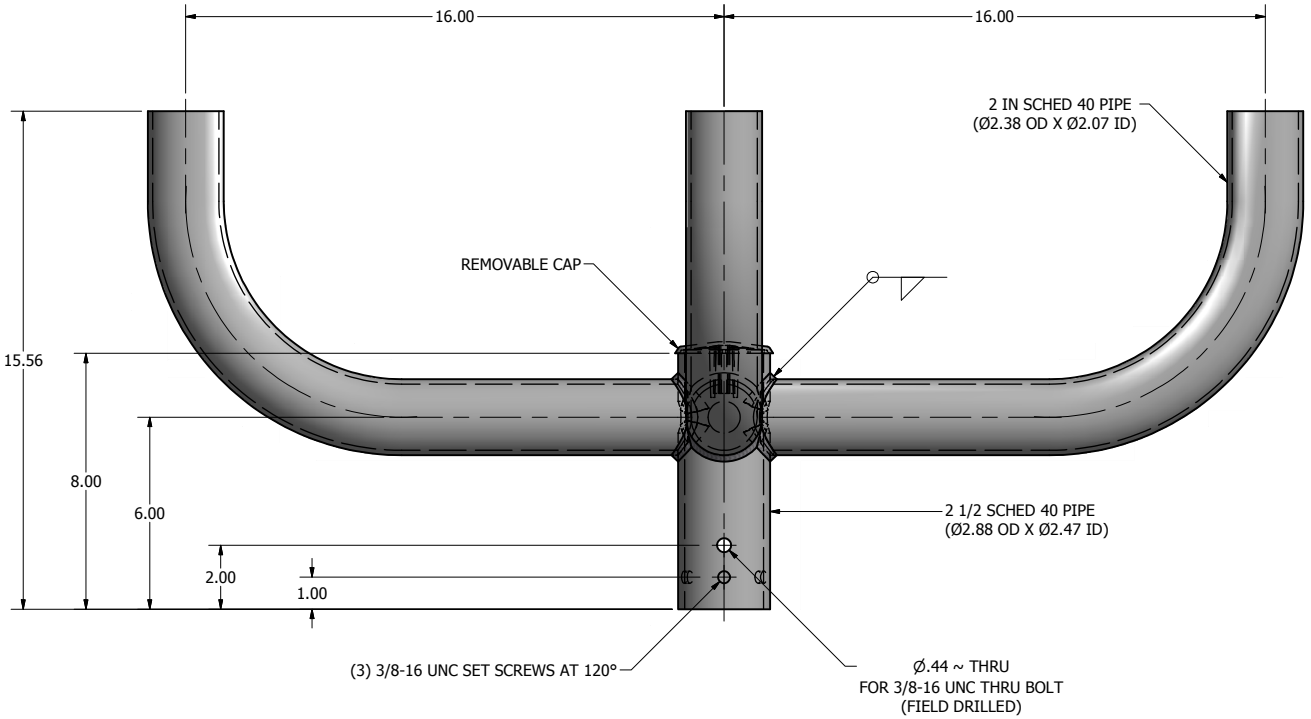

VIEW A-A
POST TOP BULLHORN TOP VIEW

NOTE: SERIES PTB POLE TOP FLOODLIGHT MOUNTING BRACKETS SLIP FIT Ø2.38 O.D. PIPE SIZE. BRACKET TENONS ARE Ø2.38 O.D. PIPE SIZE. EACH BRACKET HAS A MAXIMUM CAPACITY OF TWO, THREE, OR FOUR 1000 WATT FLOODLIGHTS, DEPENDING ON MOUNTING CONFIGURATION. SLIP FITTERS FOR Ø3.00 IN & Ø4.00 IN TENONS ARE AVAILABLE UPON REQUEST. BRACKETS ARE FINISHED TO MATCH POLE REQUIREMENTS.

BRACKETS CATALOGED ARE CONSTRUCTED OF STEEL AND ARE FOR USE ON STEEL AND ALUMINUM POLES. IF ALUMINUM BRACKETS ARE REQUIRED FOR ALUMINUM POLES, PLEASE CONTACT YOUR REPRESENTATIVE.

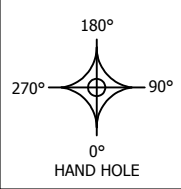

DRAWN: L. GRUNIS	2/6/2017
CHECKED	
REVISION:	DATE:
APPROVED:	
QUOTE:	
S.O.#	
REF:	SCALE: NONE

UNITED LIGHTING STANDARDS
A DWH COMPANY

23171 Groesbeck Hwy.
Warren, MI 48089
P: (586) 774-5650 | F: (586) 774-5706
www.unitedlightingstandards.com

SOME GEOGRAPHICAL AREAS HAVE SPECIAL WIND CONDITIONS THAT CAN CREATE WIND INDUCED VIBRATIONS CAUSING A FATIGUE PROBLEM. NO METHOD HAS YET BEEN FOUND FOR PREDICTING DESTRUCTIVE LIGHTING POLE VIBRATION. THESE CONDITIONS ARE UNIQUE AND CANNOT BE GUARANTEED AGAINST, AND ARE THE RESPONSIBILITY OF A LOCAL SITE ENGINEER.		
TITLE:		
CATALOG:		
DWG NO: PTB-4	SIZE: C	SHEET 1 OF 1