

Project: _____
 Fixture Type: _____ Quantity: _____
 Customer: _____



Catalog Logic

BD4SQSTL12.7 - **BAA** - **CCS1201** - **41**

Pole Accessory Clamshell Finish

Catalog Number

1 2 3 4

See page 2 for more ordering info

1	Item Number	OD	Height	Wall	80 MPH	100 MPH
	BD4SQSTL12-7	4.00"	12'	7g	36.50	20.00
	BD4SQSTL13-7	4.00"	13'	7g	33.10	18.00
	BD4SQSTL14-7	4.00"	14'	7g	29.20	16.00
	BD4SQSTL15-7	4.00"	15'	7g	26.30	14.40
	BD4SQSTL16-7	4.00"	16'	7g	23.40	12.80
	BD4SQSTL17-7	4.00"	17'	7g	21.00	11.70
	BD4SQSTL18-7	4.00"	18'	7g	18.70	10.90

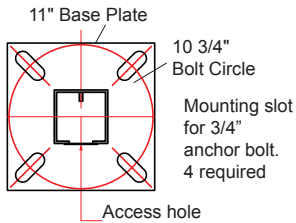
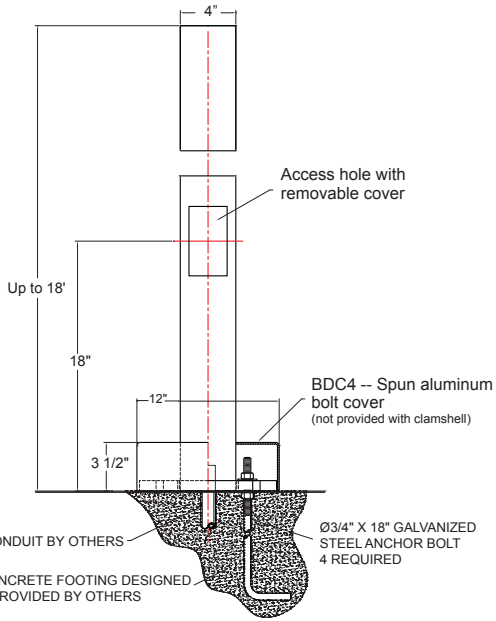

MOUNTING DETAIL

Various heights and fixture configurations may require a different bolt circle. Consult factory for specific bolt circle required.

Material

One-piece non-tapered round shaft of low carbon steel (ASTM-A500 Grade B, 42,000 PSI min. yield) with one flush-welded vertical seam. Shaft is welded to a flat steel anchor base (ASTM-36, 36,000 PSI min. yield). Wall thickness is 7 gauge.

Mounting

Four anchor bolts provided are 3/4"x18". Anchor bolts, nuts and washers are hot dipped galvanized steel. Spun aluminum bolt cover provided.

Access

All poles are provided with a hand access opening and cover. Hand hole cover is secured by two stainless steel machine screws. (Tamper-proof screws provided upon request).

Grounding

All poles are provided with an aluminum grounding lug integrated to inner wall of shaft, 180 degrees to hand hole. Grounding lug is drilled and tapped to accommodate 1/4"-20 stainless steel machine screw.

Pole Height

Maximum pole height is 18-feet.

Accessories

Banner arms, ladder rests, signage, flag pole holder and GFI receptacles are optional.

Finish

A polyester powder coat high quality finish is electro-statically applied and baked at 430° for exceptional durability and color retention. Products undergo an intensive five-step cleansing and pretreatment process for maximum paint adhesion.

Marine grade finish provides superior salt, humidity, and UV protection. This coating withstands up to 3000 hours of continuous salt spray, comes with a 5-year warranty and is available in either a textured or gloss surface.













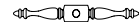
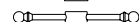

Project: _____

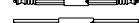

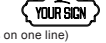





















Fixture Type: _____ Quantity: _____

Customer: _____



Illuminating
ENGINEERING SOCIETY

2 ACCESSORIES	
GF115	(15 amp GFCI receptacle outlet) 
GF120	(20 amp GFCI receptacle outlet)
GFI-WPU	(20 amp GFCI receptacle with weather proof in-use cover)
BAA	(Cast Banner Arm A for 24" wide banner) 
BAB	(Cast Banner Arm B for 30" wide banner) 
BAC	(Cast Banner Arm C for 30" wide banner) 
LR1	(Cast Ladder Rest 1) 
LR3	(Cast Ladder Rest 3) 
LR4	(Cast Ladder Rest 4) 
LR5	(Cast Ladder Rest 5) 
SIGN A	(Cast Sign A; 30" x 9", 8 letters/numbers on one line; requires Banner Arm to hang) 
SIGN B	(Cast Sign B; 31" x 7", 12 letters/numbers on one line; requires Banner Arm to hang) 
SIGN C	(Cast Sign C; 27" x 11", two rows of 8 letters/numbers on each line; requires Banner Arm to hang) 
SIGN D	(Cast Sign D; 11" x 6 1/2", 4 letters/numbers on one line) 
SIGN E	(Cast Sign E; comes with pole clamp, 24 1/2" x 6", 9 letters/numbers on one line) 
FPH1	(Flag Pole Holder) 
TP	(Tamper Proof Screws)
BDC	(Spun Aluminum Bolt cover) 
SBDC	(Split Bolt Cover) 

3 2-PIECE CLAMSHELLS					
CCS0300		CCS1302		CCS2902	
CCS0509		CCS1501		CCS2903	
CCS0701		CCS1502		CCS5301	
CCS0702		CCS1504		CCS5401	
CCS0900		CCS1509		CCS5509	
CCS1100		CCS1607		CCS6303	
CCS1201		CCS1608		CCS6502	
CCS1301		CCS1902		CCS9103	

4 FINISHES					
Standard Grade	Marine Grade		Standard Grade	Marine Grade	
40	NA	Raw Unfinished	53	100	Copper Clay
41	101	Black	56	109	Silver
42	102	Forest Green	61	106	Black Verde
43	114	Bright Red	70	118	Painted Chrome
44	107	White	71	105	Painted Copper
45	112	Bright Blue	72	108	Textured Black
46	123	Sunny Yellow	73	125	Textured Architectural Bronze
47	120	Aqua Green	76	121	Textured Silver
49	NA	Galvanized	77	127	Textured White
50	111	Navy	78	124	Textured Silver
51	103	Architectural Bronze	10	130	Aspen Green
52	104	Patina Verde	11	131	Cantaloupe
12	133	Lilac	13	132	Putty

Consult factory for additional paint charges and availability