

# RETROFIT KIT 30W HE 2X4'



PRO



- ⌚ Easy 3-5 minutes installation
- ⌚ Universally compatible to upgrade 2x4' troffer and louver
- ⌚ Exceptional efficacy 143 LPW
- ⌚ 120-277V circuit and 0-10V dimming control compatible
- ⌚ High performance lighting distribution and low glare lens
- ⌚ Extra long 100,000 hour lifetime

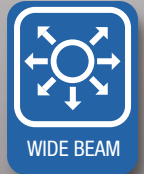
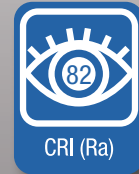

## EFFICIENCY AT WORK



# RETROFIT KIT 30W HE 2X4'

## INSTALLATION GUIDE

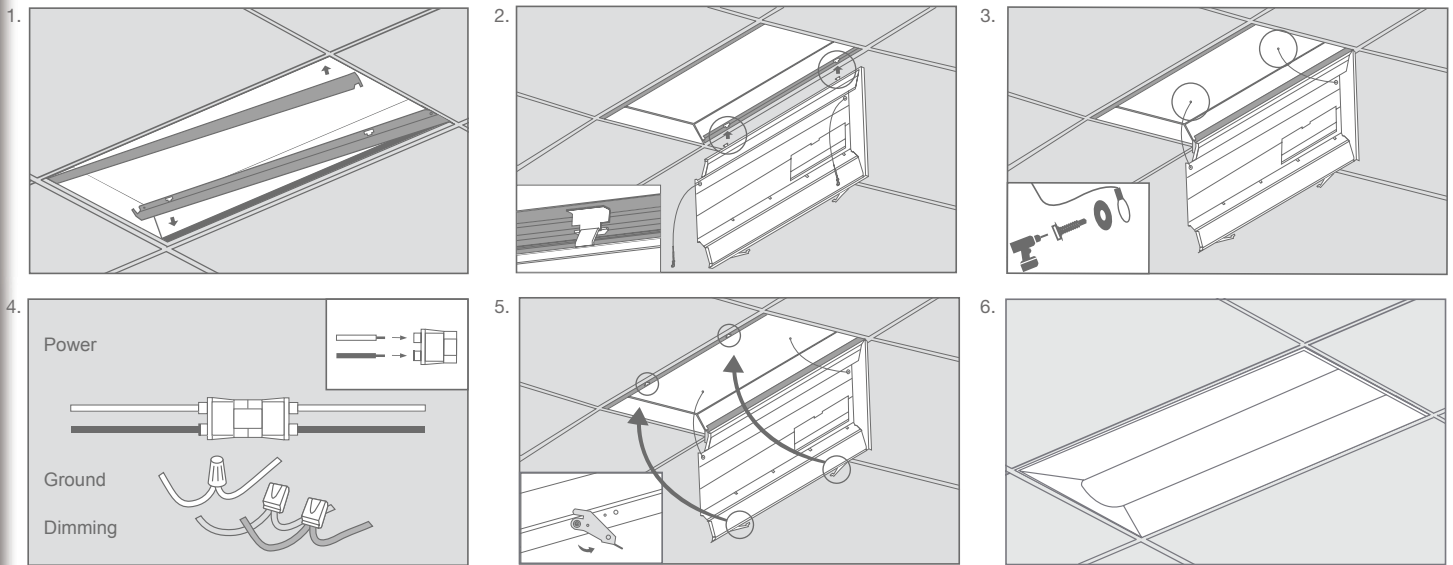

### RETROFIT KIT INSTALLATION

- Step 1.** Make sure the **POWER IS TURNED OFF** at the source to the location at which you are installing the product.
- Step 2.** Remove existing lamps, door frame (if applicable), reflector and ballast cover.
- Step 3.** Gently lift the original luminaire housing and slide in both side mounting brackets between the housing and the T-grid. (fig. 1)
- Step 4.** Hang the retrofit kit body by hooking the T-hinges into the respective slots on one of the mounting brackets. (fig. 2)
- Step 5.** Attach the safety cables to the original luminaire housing using the self-tapping hex head screws and washers provided. (fig. 3)
- Step 6.** Connect the retrofit kit power to the AC power. Connect the power supply to the retrofit kit. (fig. 4)
- Step 7.** Close the retrofit kit by pushing it up and securing both latches. (fig. 5)
- Step 8.** Return power back to the source and installation is complete. (fig. 6)

## SPECIFICATIONS

Product	28341	28342	28343
Model	30TROFKIT24DIM/830/277V	30TROFKIT24DIM/835/277V	30TROFKIT24DIM/840/277V
<b>Type</b>	2x4' Troffer Retrofit Kit	2x4' Troffer Retrofit Kit	2x4' Troffer Retrofit Kit
<b>Power (W)</b>	30	30	30
<b>Voltage - Frequency</b>	120-277V 50-60Hz	120-277V 50-60Hz	120-277V 50-60Hz
<b>Color Temp. (ANSI)</b>	Warm White 3000K	Neutral White 3500K	Cool White 4000K
<b>CRI (Ra)</b>	82	82	82
<b>Typical lumens (lm)</b>	4200	4200	4300
<b>Efficacy (LPW)</b>	140	140	143
<b>Beam Angle</b>	120°	120°	120°
<b>Dimmable</b>	Yes	Yes	Yes
<b>Power Factor</b>	0.9	0.9	0.9
<b>THD</b>	<20%	<20%	<20%
<b>Rated Lifetime - L70 (hrs.)</b>	100,000	100,000	100,000
<b>Rated Lifetime - L90 (hrs.)</b>	44,000	44,000	44,000
<b>L x W x H (w/ brackets)</b>	47.83"x23.94"x2.76"(1215x608x70mm)	47.83"x23.94"x2.76"(1215x608x70mm)	47.83"x23.94"x2.76"(1215x608x70mm)
<b>L x W x H (w/o brackets)</b>	46.77"x20.59"x2.76"(1188x523x70mm)	46.77"x20.59"x2.76"(1188x523x70mm)	46.77"x20.59"x2.76"(1188x523x70mm)
<b>Weight (lb. / g)</b>	18.83lb. / 8.54kg	18.83lb. / 8.54kg	18.83lb. / 8.54kg

# RETROFIT KIT 30W HE 2X4'



## PRODUCT ORDERING INFORMATION

Must Select				Options (Factory Installation): Select or Leave Blank		
Power	CRI	CCT	Voltage	Step Dimming	Sensor	EM Backup
30TROFKIT24DIM 30W	8 82	30 3000K	277V 120-277V	(Blank) None	(Blank) None	(Blank) None
		35 3500K		STEPDIM Step Dimming 100/50	OCCDIM Microwave Sensor	EM 10W EM Backup
		40 4000K				

Ex. 30TROFKIT24DIM/840/277V/OCCDIM/EM

## ACCESSORY ORDERING INFORMATION

Model	Product	Description
SENSORRC	97881	Remote Control for OCCDIM