

Date:	
Project Name:	
SKU #:	

## CHB-N™

Circular High Bay



### MOUNTING OPTIONS



Hanging Hook  
Mount  
(Standard)  
[HM]



Pendant Mount  
[Stem Not Included]  
(Option)  
[PM]



Surface Mount  
(Option)  
[SM]



Loop Mount  
[Chain Not Included]  
(Option)  
[LM]

## APPLICATIONS

Commercial and Industrial

## FEATURES

### Construction

- UniBody Aluminum Alloy Housing
- Advance Thermal Management

### Finish

- White
- Grey

### Electrical & Technical

- Input Voltage: 100-277V  
277-480V
- Input Frequency: 50/60Hz
- Projected Life: L70 > 100,000 hrs
- PF: >0.9
- CRI: >80
- THD: <20%
- CCT: 4000K or 5000K
- Operating Temp.: -22°F ~ 122°F
- Surge Protection: 6kV
- IP Rating: IP69K
- IK Rating: IK10
- 40W Emergency Inverter [Option]  
[120-277V Black Finish Only]

### Optical

- 120° Beam Angle
- 90° Beam Angle
- 50° Beam Angle

### Installation/Mounting

- Hanging Hook Mount [Standard]
- Pendant Mount [Option]  
[Stem Not Included]
- Surface Mount [Option]
- Loop Mount [Option]  
[Stem Not Included]

### Controls

- 1-10V Dimming

### Lumen Output

- 100W: 13,500lm
- 150W: 20,250lm
- 200W: 27,000lm

### Warranty

- 5 Year Warranty
- See warranty documentation for more information.



## ORDERING INFORMATION

Series	Wattage	CCT	Beam Angle	Input Voltage	Dimming	Finish	Mounting Option
CHB-N	100W 150W 200W	40 - 4000K 50 - 5000K	WD - 120° MD - 90° ND - 50°	U - 100-277V H - 277-480V	D - 1-10V Dimming	G - Grey W - White	HM - Hanging Mount PM - Pendant Mount SM - Surface Mount LM - Loop Mount

### Accessories

WP-EWG-040U (40W Emergency Inverter)

**DIMENSIONS**

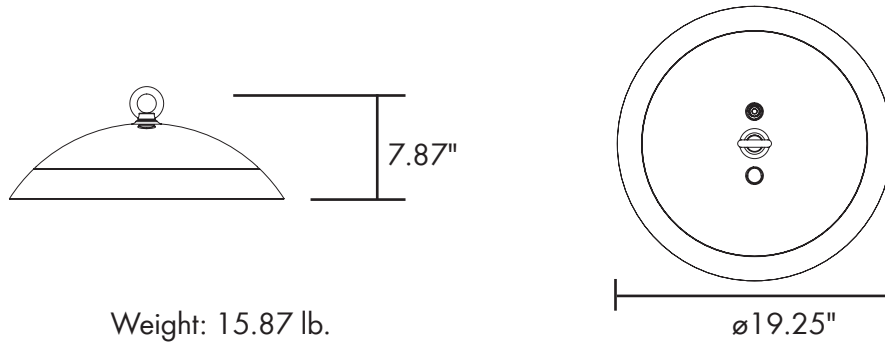

**LUMEN OUTPUT**

SKU	Wattage (W)	Delivered Lumens (lm)	Efficacy (lm/W)
CHB-N-100W-50K-WD-U-D	100	13500	135
CHB-N-150W-50K-WD-U-D	150	20250	135
CHB-N-200W-50K-WD-U-D	200	27000	135

**ACCESSORIES**



40W  
Emergency Inverter  
(Option)  
[WP-EWG-040U]