

LED Conveyor Belt Light and General Area Light



50W fixture delivers up to 6500 lumens

Economic yet durable design

Primary applications include conveyor belts, narrow pathways as well as general wall or pole mount lighting

LED technology increases efficiency, eliminates maintenance and supports green initiatives

Key Applications

Heavy industrial conveyor belts
Catwalk lighting
Bulk material handling
Narrow pathways & walkways
Pole lighting
Wall perimeter lighting
General area lighting

Compliances

UL/cUL Listed to:

- UL 1598 Suitable for Wet Locations
- UL 1598A Marine Outside Type (Saltwater)
- UL 844 Hazardous Location
Class I, Division 2 Groups A, B, C, D
Class II, Division 2 Groups F, G
Class III
- CSA C22.2 No. 250.0
- CSA C22.2 No. 137

CE

International Dark Sky Association approved (WW options)

IP63 rated (wall mount)

IP65 rated (pole mount)

NEMA 4X (MAR option only)

Specifications

Construction	Marine grade, cast aluminum housing
Finish	Gray polyester powder coat
Hardware	Marine grade 316 stainless steel
Lens	UV- and impact-resistant PMMA Type II optic Full cutoff, zero uplight
Light source	Standard option up to 6500 lumens, CCT 5000K Warm white option up to 5800 lumens, CCT 3000K 50W 50,000 hour rated life
Power source	120-277V, 50-60Hz Fully potted Replaceable Overload, over-voltage, over-temperature and short-circuit protection
Power factor	>.9 at 120V
Wiring	Stranded wire leads Water-tight grommet - standard Water-tight cord grip (MAR) Water-tight conduit hub (HAZ)
Ambient operating temperature	-40°C to +50°C
Mounting	Wall or pole mount capable Accommodates NPS 1.25 inch (1.66 inch OD)/ DN 32 mm (42 mm OD)
Weight	4.0 lb (1.8 kg)
Warranty	3 years

For IES files, see website or contact factory



This product complies with domestic preference requirements such as BAA or TAA. For additional information, visit phoenixlighting.com or consult your representative.

CVO Series

LED Conveyor Belt Light and General Area Light

Dimensions

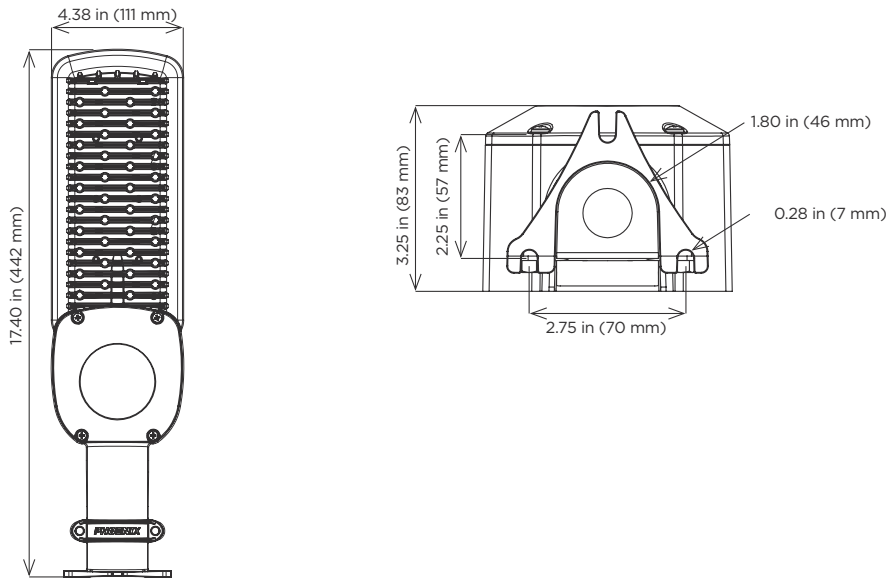

Ordering Information

Example: CVO-48LED

Fixture	Wattage	Options
CVO	48LED	HAZ
		MAR ²
		WW ¹

Voltage

48LED 50W, up to 6500 lumens

Generation

HAZ UL 844 listed
MAR² UL 1598A Marine Outside Type (Saltwater) listed
WW¹ Warm white LEDs, up to 5800 lumens

Notes

- 1 International Dark Sky Association approved
- 2 NEMA 4X (MAR option only)

Special Projects: We may be able to accommodate your special projects, so please don't hesitate to ask about additional options. Minimum order quantities and/or extended lead times will apply. Contact your Phoenix representative with specific inquiries.

Accessories (order separately)

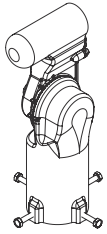

Adjustable Tenon Mount Kit

CVO-TN-MNT-ADJ

Adjustable in 5° increments

Accommodates NPS 1.00 inch pipe (1.32 inch OD)/DN 25 mm (34 mm OD),

NPS 1.25 inch pipe (1.66 inch OD)/DN 32 mm (42 mm OD),
NPS 1.50 inch pipe (1.90 inch OD)/DN 40 mm (48 mm OD) and
NPS 2.00 inch pipe (2.38 inch OD)/DN 50 mm (60 mm OD)

Lens Kits

CVO-LNS-100 (100° lens kit)

Note: Contact factory for additional optic options

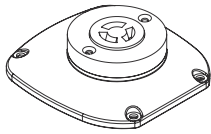

Photocell Receptacle Kit

CVO-PCR

Note: When installed, fixture will be IP63 rated; not suitable for use with HAZ or MAR options



Safety Cable Kit

CVO-SFCB

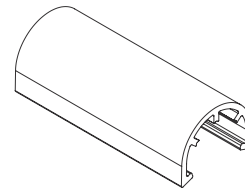

One Inch Adaptor Bracket

CVO-AB1