

VERSA COMMERCIAL

6" LED COMMERCIAL DOWNLIGHT REMODEL

JOB INFORMATION	TYPE:
	CATALOG NO.
	PROJECT NAME:
	COMMENTS:
	PREPARED BY:

FEATURES

USE OF PRODUCT

The 6" Versa Commercial LED Downlight Series is suitable for use in ecologically sensitive areas, sea turtle nesting areas, migratory corridors and Dark Sky friendly communities. Light produced by the Amber LED is visible to humans and can be safely used for outdoor lighting applications, but it is virtually undetectable to sea turtles and other forms of marine wildlife.

VERSA COMMERCIAL FEATURES

Color Temperature: Amber
 Wattage: 17 W
 Color Rendering Index: 93+ CRI
 R9: 60+
 Optical Lens: 30°, 50°
 Filter Accessories: Solite, frosted or honeycomb
 LED Life: 50,000 Hours
 LED Type: Cree LED
 Driver Info: 120-277V, 50/60 Hz, PF>0.9, THD<0.20
 Versatility: Interchangeable reflector/trim ring, optics & filters
 Warranty: 5 year limited warranty

LED ENGINE

Amber color temperature for optimal spectral power distribution for preservation of endangered sea turtle populations.

FRAME CONSTRUCTION

This fixture is well shielded, full cut-off, and downward directed only. Constructed from 16 gauge heavy duty powder coated cold rolled steel frame with a large access junction box.

OPTICAL LENS (Field Replaceable)

Field replaceable optical lens available in 30°, 50°.

FILTER ACCESSORIES

A multitude of filter accessories are available to achieve a particular light effect. Available in frosted, honeycomb, or solite filter options.

DIMMING

Available in 8 driver selections. (ID) Standard all-inclusive ELV, Triac, and 0-10V dimming driver called Intelligent Drive, 120-277V. (PEQ0) Lutron Hi-Lume Premier Ecosystem 0.1% w/soft on, fade to black dimming, 120-277V. (LDE1) Lutron Hi-Lume 1% Ecosystem with soft on, fade to black dimming, 120-277V. (L3DA) Hi-lume 1% EcoSystem/3-Wire L3D Driver (LTE) Hi-Lume 1% 2-wire, 120V (EEI) eldoLED Eco 1% Dim (0-10V), 120-277V. (EDIO) eldoLED Solo 0.1% Dim (0-10V), 120-277V. (EDID) eldoLED Solo 0.1% Dim (DALI), 120-277V.

VERSATILITY

The Versa Commercial LED Downlight series provides for interchangeable reflectors and trims in round/square with an assortment of finishes to achieve a particular look. The ability to field install and/or replace various reflectors, trims, optics & filters makes the Versa Commercial Downlight Series the most flexible commercial downlight in the industry.

LABELS/COMPLIANCE/WARRANTY

- CSA Listed for US and Canada
 - Certified FWC
 - 5 year limited warranty.

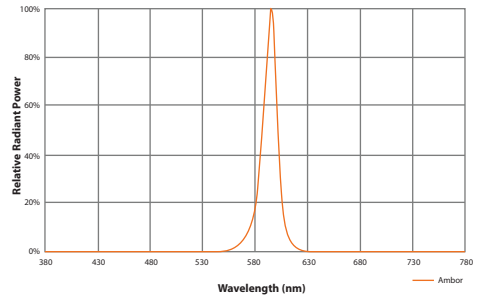

Color	Dominant Wavelength Range				Minimum Luminous Flux (lm) @ 350 mA	
	Minimum		Maximum		Group	Flux (lm)
	Group	DWL (nm)	Group	DWL (nm)		
Amber	A2	585	A3	595	P4	80.6
					P3	73.9
	N4	P2	67.2			
		N4	62			
		N3	56.8			



ORDERING INFORMATION

Series	Lumens	Color Temp	Voltage	Dimming	Optical Lens ⁵
RVC6	5 - 500 lm	A - Amber	UNV - 120-277V 1 - 120V 3 ¹ - 347V	ID ² - Standard all-inclusive ELV, Triac, and 0-10V dimming driver (Intelligent Drive) LDE1 - Lutron Hi-Lume 1% Ecosystem with soft on, fade to black dimming PEQ0 - Lutron Hi-Lume Premier Ecosystem 0.1% w/soft on, fade to black dimming LTE ³ - Hi-Lume 1% 2-wire L3DA - Hi-lume 1% EcoSystem/3-Wire L3D Driver EEI ⁴ - eldoLED Eco 1% Dim (0-10V) EDIO ⁴ - eldoLED Solo 0.1% Dim (0-10V) EDID ⁴ - eldoLED Solo 0.1% Dim (DALI)	30 - 30° Beam 50 - 50° Beam



Reflector	Trim	Frame	Frame Accessories	Options
6RW - White 6RS - Specular Clear 6RH - Haze 6RB - Black MTO - Made to order	6TW - White 6TS - Specular Clear 6TH - Haze 6TB - Black MTO - Made to order	FR - Remodel	C - C Channel bar hanger B - Flat bar hanger WJ - Wood joist	EI8 - Emergency Battery with Integral Switch (800 Lumens) ER8 - Emergency Battery with Remote Switch (800 Lumens) EI17 - Emergency Battery with Integral Switch (1700 Lumens) ER17 - Emergency Battery with Remote Switch (1700 Lumens) WL - Wet Location F - Frosted filter H - Honeycomb S - Solite filter

6" LED COMMERCIAL DOWNLIGHT REMODEL

1. Step down transformer required.
 2. Intelligent Drive is the standard driver.
 3. 120V only.
 4. Must specify logarithmic or linear eldoLED driver.
 5. Without standard frosted acrylic diffuser.



www.rayonlighting.com
 info@rayonlighting.com

Tel: 323.446.2626
 Fax: 323.446.2606

Specification and product availability
 subject to change without notice

07/19

FRAME ACCESSORIES

WJ

4" up to 8" CKOs

Slotted Holes allow for an easier installation

Wood Joist

Fits up to 26" stud spacings

Plate is offset, allowing for adjustability with irregular stud spacing

B

27"

1/2"

Flat Bar Hanger

C

25-3/16"

1-6/16"

C Channel Bar Hanger

VERSA COMMERCIAL

4" LED COMMERCIAL DOWNLIGHT
NEW CONSTRUCTION

PROJECT:

MODEL #:

LOCATION:

CONTACT:

DIMENSIONS

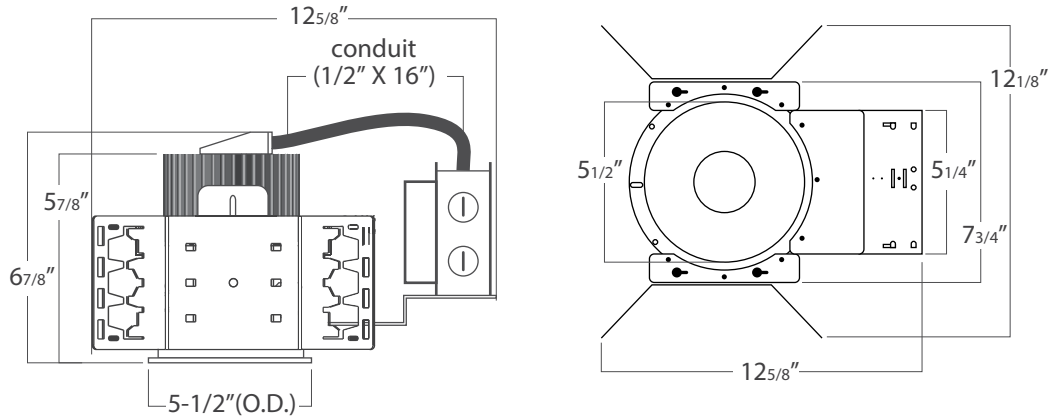

REFLECTOR/TRIM DIMENSIONS

REFLECTOR/TRIM



4" LED COMMERCIAL DOWNLIGHT NEW CONSTRUCTION

VERSA COMMERCIAL

4" LED COMMERCIAL DOWNLIGHT
NEW CONSTRUCTION

PROJECT:

MODEL #:

LOCATION:

CONTACT:

ANATOMY

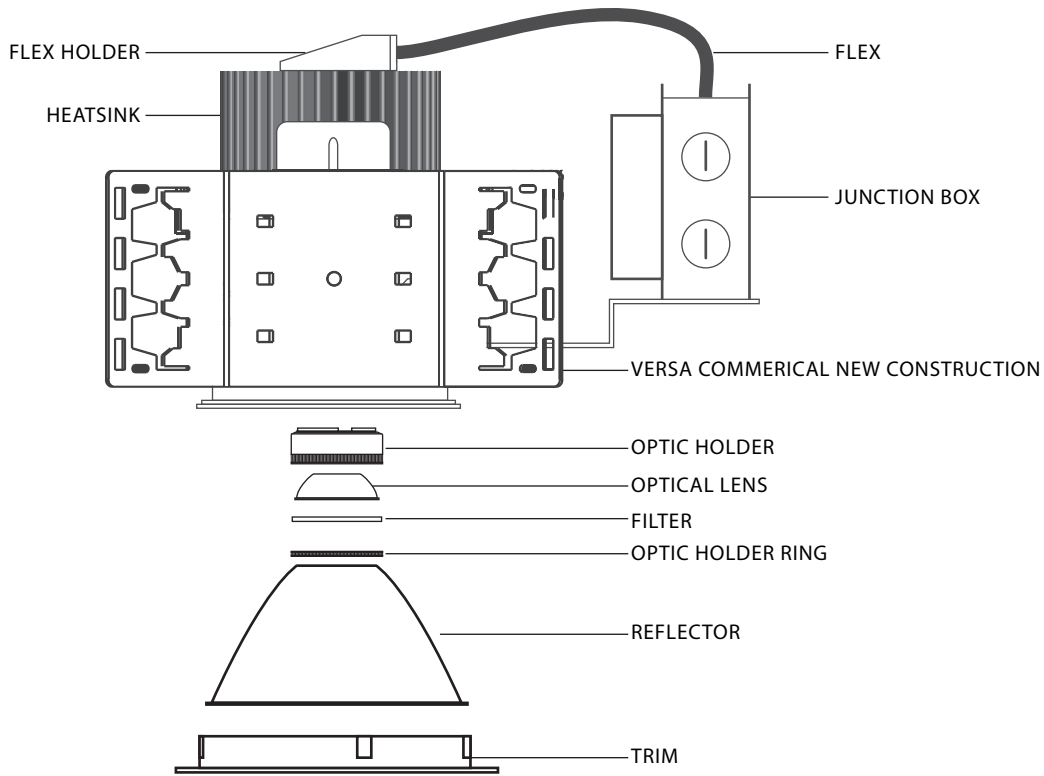

4" LED COMMERCIAL DOWNLIGHT NEW CONSTRUCTION