

tradeSELECT®

FEATURES

- Switchable Lumen technology:
5500/4100/3400 lumens (2x4)
4000/3300/2800 lumens (2x2)
- 2x2 and 2x4 sizes
- 80 CRI
- 0–10V dimming to 10%
- Recessed, surface, or cable mount
- Universal voltage (120–277V)
- IC rated
- Suitable for ISO Class 5–9 positive pressure and negative cleanrooms



SPECIFICATIONS

CONSTRUCTION

- Extruded aluminum frame has a matte white finish and smooth frame-to-lens transition

OPTICS

- Acrylic blend light guide with frosted/ textured outer lens provides edge to edge illumination without pixelation or bright spots

INSTALLATION

- Integral T-bar clips for secure mounting to grid ceiling
- For surface/cable mount applications use surface/cable mount kit accessories
- For plaster or sheet rock installations, use flange kit

ELECTRICAL

- 54,000 hour LEDs at L70 for reduced maintenance
- Switchable Lumen technology allows for easy field-adjustable lighting output with three level switch located on back of panel
- Switchable Lumen fixtures ship at the highest lumen output setting
- Operates at 120-277V input
- 0–10V dimmable driver, down to 10%

CERTIFICATIONS

- All luminaires are built to UL 1598 standards and bear appropriate cULus labels
- CSA certified to UL 924 standards with battery pack
- UL Sanitation Certified to NSF 2 Food Equipment standard for non-food zones

CERTIFICATIONS (CONTINUED)

- Damp location label standard
- Tested in accordance with ISO 14644-1; suitable for ISO Class 5–9 positive and negative pressure clean rooms
- Adheres to LM79, LM80, and TM21 industry standards for photometrics and lifetime calculations
- DLC® (DesignLights Consortium Qualified, with some Premium Qualified configurations. Please refer to the DLC website for specific product qualifications at www.designlights.org)

WARRANTY

- 5 year warranty

KEY DATA	
Lumen Range	2876–6143
Wattage Range	25–56
Efficacy Range (LPW)	102–137
Reported Life (Hours)	L70/54,000

CFP

EDGE-LIT FLAT PANEL

ORDERING GUIDE

Catalog No.	Part #	UPC	Description	Delivered Lumens	Watts	LPW
CFP22-40/33/2835	93114032	78531140595	2x2 Edge-Lit Flat Panel, 4000/3300/2800 Switchable Lumens, 3500K	4281	40	108
				3338	30	113
				2876	25	115
CFP22-40/33/2840	93114033	78531141004	2x2 Edge-Lit Flat Panel, 4000/3300/2800 Switchable Lumens, 4000K	5001	40	125
				3905	30	131
				3382	26	133
CFP24-55/41/3440	93114035	078531141004	2x4 Edge-Lit Flat Panel, 5500/4100/3400 Switchable Lumens, 4000K	6143	50	122
				5030	40	125
				3945	31	128

Made to Order (MTO) options:
 Add **ELL14¹** (Emergency Battery Pack Installed, 1400 Lumens) or **C588** (5-wire Flex) to any stocked option.
 Examples: **CFP14-55/41/3435-ELL14**; **CFP14-55/41/3435-C588**

Accessories (Order Separately)	
PLD10M	Dual-Lite® Emergency LED Battery Pack, field installed ¹
PLRTS	Remote Test Switch/Charge Indicator Module (fits single-gang box)
FK22	2x2 Single Flange Kit
FK24	2x4 Single Flange Kit
PSMK-22	2x2 Flat Panel Surface Mount Kit
PSMK-24	2x4 Flat Panel Surface Mount Kit
CFPCM36Y SC5F-KIT	36" Cable Mount Kit for 1' or 2' wide Cable Mount fixtures, 5-wire

Notes:
 1 Fixtures with Emergency Battery Pack require a remote-mounted test switch, we suggest the Dual-Lite PLRTS.

CFP

EDGE-LIT FLAT PANEL

DIMENSIONS

2'x2' Recessed Mount

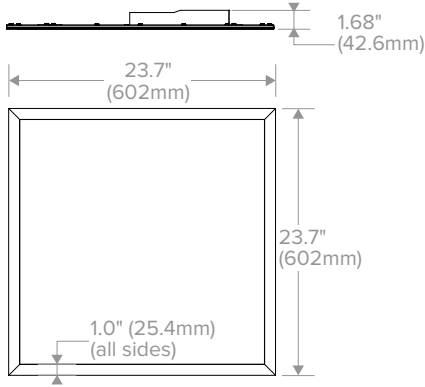

2'x2' Surface Mount

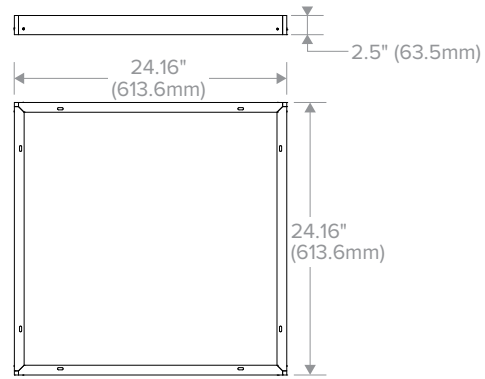

2'x4' Recessed Mount

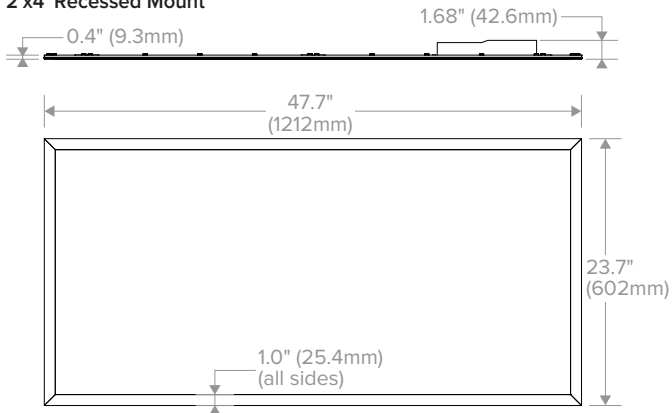

2'x4' Surface Mount

