

CR Series

CR14™, CR22™, and CR24™ Architectural LED Troffer - Version B

Rev. Date: V5 07/12/2023

Product Description

The CR Series architectural LED troffers deliver up to 137 lumens per watt of exceptional indirect low glare, 90 CRI light from 2,030 to 5,070 lumens. This breakthrough performance is achieved by combining the high efficacy and high-quality light of Cree TrueWhite® Technology with a unique thermal management design. Its design makes the CR Series perfect for use in commercial new construction or renovated spaces. The CR Series product family is available with 0-10V dimming to 1%, SmartCast® Technology, or Lutron EcoSystem® Enabled dimming options. The CR Series product family is available in warm, neutral, cool, or daylight color temperatures with tunable white offered in luminaires with SmartCast wireless or Lutron T-Series.

Performance Summary

Utilizes Cree TrueWhite® Technology
Room-Side Heat Sink
Efficacy: Up to 137 LPW
Initial Delivered Lumens: 2,030 - 5,070 lumens
Input Power: 16 - 38 watts
CRI: 90+
R9: > 60
CCT: 3000K, 3500K, 4000K, 5000K, Tunable White (SmartCast® Technology, Lutron T-Series)
Input Voltage: 120-277 VAC or 347 VAC
Limited Warranty*: 10 years for luminaire, SmartCast controls, and Lutron controls; up to 5 years for SmartCast® accessories; 1 year for luminaire accessories
Limited Warranty Emergency Back Up (EB) Battery: 1 Year on Battery Back Up. Test regularly in accordance with local codes
Controls: 0-10V Dimming, SmartCast Wireless with Adjustable CCT option, Lutron Vive, Lutron EcoSystem, Lutron T-Series 2 Channel Tunable White
Mounting: Recessed*; surface or suspended w/surface mount kit accessory

Assembled in the USA by Cree Lighting from US and imported parts

* See <http://creelighting.com/warranty> for warranty terms

* Acceptable for use with standard 9/16 T-Bar or larger when installed per installation instructions. Consult factory for non-standard grid applications

CR24

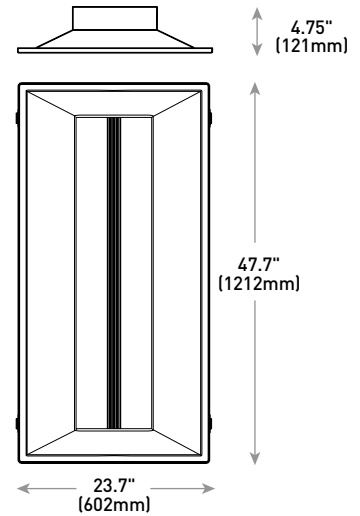

NOTE: Use of Expanded Junction Box will expand the depth to 6.7" (170mm) and Emergency Backup will expand the depth to 5.2" (131mm).

Refer to page 5 for additional sizes, controls, EB option and weights.

Luminaire	Weight
2x4	18.2 lbs. (8.3kg)

Ordering Information

Example: CR24-B-40L-940-UNV-10V1

CR	B		Lumen Package	CRI/CCT	Voltage	Control	Options
CR	14 1x4 24 2x4	B	22L 2,200 Lumens	930 90 CRI, 3000K	UNV Universal 120-277V 34 347V	10V1 0-10V Dimming to 1% LDE1+ Lutron HiLume 1% EcoSystem LED Driver with Soft-on, Fade to Black Dimming Technology - Available only with UNV voltage PSQ0+ Lutron T-Series 2 Channel Tunable White - Requires 9ACK CRI/CCT option - Available only with UNV voltage - Available only with 32L or 40L lumen packages SC1 SmartCast Wireless Technology with 1% Dimming, Integral Motion and Ambient Sensors - Utilizes a multifunction sensor - For adjustable CCT functionality, luminaire must be ordered with 9ACK CRI/CCT option with 32L or 40L lumen packages - Available only with UNV voltage VDO+ Lutron Vive Wireless Integral Fixture Control w/Occupancy and Daylight Sensing - Utilizes a multifunction sensor - Available only with UNV voltage VRF+ Lutron Vive Wireless Integral Fixture Control (RF only) - Available only UNV voltage	6W5 Power Whip - 6', 5-Wire - Available only with UNV voltage - Not available with EB 6W6 Power Whip - 6', 6-Wire for use with luminaires w/EB option - Available only with UNV voltage CP Chicago Plenum EB Emergency Backup - Available only with UNV voltage - Provides 10W and 90 minutes of emergency operation - GT and EB cannot be used together GT Generator Transfer Device - Available only with UNV voltage - GT and EB cannot be used together - Not available with power whip options
			40L 4,000 Lumens	940 90 CRI, 4000K			
	22 2x2		31L 3,100 Lumens	935 90 CRI, 3500K			
			50L 5,000 Lumens	940 90 CRI, 4000K			
			32L 3,200 Lumens	950 90 CRI, 5000K			

* More information on Lutron controls can be found at lutron.com.



US: creelighting.com (800) 236-6800

Canada: creelighting-canada.com (800) 473-1234

CREE LIGHTING®

Product Specifications

SMARTCAST® TECHNOLOGY

SmartCast® Technology is the most intuitive and easiest to install intelligent light solution on the market. SmartCast® Technology delivers up to 70% energy savings at up to half the cost of other solutions. Luminaires combine best-in-class light with onboard sensors and intelligence to deliver a better light experience. Extreme energy productivity, code compliance and a better light experience without any extra design, installation or setup work.

CREE TRUEWHITE® TECHNOLOGY

A revolutionary way to generate high-quality white light, Cree TrueWhite® Technology is a patented approach that delivers an exclusive combination of 90+ CRI, beautiful light characteristics, and lifelong color consistency, all while maintaining high luminous efficacy – a true no compromise solution

CREE LIGHTING LED TECHNOLOGY

Cree Lighting's total systems approach to product development is a comprehensive engineering philosophy that combines the most advanced LED sources, driver technologies, optics and forms. The result is highly-reliable luminaire solutions for both indoor and outdoor applications that reduce energy use, extend lifetimes, and maximize illumination performance and quality.

ROOM-SIDE HEAT SINK

An innovative thermal management system designed to maximize cooling effectiveness by integrating a unique room-side heat sink into the diffusing lens. This breakthrough design creates a pleasing architectural aesthetic while conducting heat away from LEDs in a temperature-controlled environment. This enables the LEDs to consistently run cooler, providing significant boosts to lifetime, efficacy, and color consistency.

CONSTRUCTION & MATERIALS

- Durable 22-gauge steel housing with standard troffer access plate for electrical installation
- One-piece lower reflector finished with a textured high reflectance white polyester powder coating creates a comfortable visual transition from the lens to the ceiling plane
- Not for installation within 3" (76mm) of insulation
- Includes t-bar clips and holes for mounting support wires (by others)
- May be surface mounted or suspended w/surface mount kit accessory
- Individual luminaires may be mounted end to end for a continuous row of illumination

OPTICAL SYSTEM

- Unique combination of reflective and refractive optical components achieves a uniform, comfortable appearance while eliminating pixelation and color fringing
- Components work together to optimize distribution, balancing the delivery of high illuminance levels on horizontal surfaces with an ideal amount of light on walls and vertical surfaces. This increases the perception of spaciousness
- Diffusing lens integrated with upward-facing LED strip eliminates direct view of LEDs while lower reflector balances brightness of lens with the ceiling to create a low-glare high angle appearance

ELECTRICAL SYSTEM

- Power Factor:** > 90% at full load (and 120-240V for 20L, 22L, 31L and 32L)
- Input Power:** Stays constant over life
- Input Voltage:** 120-277V or 347V, 60Hz
- Operating Temperature Range:** 0°C - + 35°C (32°F - + 95°F)
- Total Harmonic Distortion:** < 20% at full load
- 10V Source Current:** 0.2mA

CONTROLS

- Continuous dimming to 1% with 0-10V DC control protocol. For use with Class 1 or Class 2 dimming systems
- Reference <https://cree.widened.net/s/nfqmqmchnk/0-10v-step-and-les-controls-options-spec-sheet-cr-flex-zr-troffers-ls-ur-styllus-ws-cdr-kbl> for recommended dimming controls and wiring diagrams

REGULATORY & VOLUNTARY QUALIFICATIONS

- cULus Listed (UL1598)
- Suitable for damp locations and plenum use
- Designed for indoor use only
- Type NON-IC in accordance with Article 410 of the NEC and UL 1598
- Requires minimum 90°C supply conductors
- Drivers and LEDs are UL Recognized in accordance with UL8750
- Meets NEMA C82.77 standards
- UL924 (EB Option); Maximum mounting height: 10.0'(3.0m)
- EB option meets CA Title 20 Appliance Regulations
- CCEA approved when ordered with CP option
- RoHS compliant. Consult factory for additional details
- Meets FCC Part 15, Subpart B, Class A limits for conducted and radiated emissions
- Assembled in the USA by Cree Lighting from US and imported parts
- Meets Buy American requirements within ARRA
- DLC Premium qualified versions available. Exceptions apply for CR24 w/22L lumen package. CR22 w/20L and CR14 w/22L lumen packages are qualified from 120-240V only. Please refer to <https://qpl.designlights.org/solid-state-lighting> for most current information
- CA RESIDENTS WARNING:** Cancer and Reproductive Harm – www.p65warnings.ca.gov

SmartCast® Technology

INTEGRAL MOTION SENSOR

- Passive infrared (PIR)
- Coverage area:** Please refer to the PIR motion sensor coverage table
- Not intended to be mounted higher than 20 ft.
- Operation:**
 - Grouped with a wall control: Luminaire will operate in vacancy mode (manual-on/auto-off)
 - Not grouped with a wall control: Luminaire will operate in occupancy mode (auto-on/auto-off)
- Luminaires operate at full intensity until OneButton™ Setup is initiated by the Cree Lighting Configuration Tool

AMBIENT LIGHT SENSOR

- Sensor response matches response of human eye
- Not intended to be mounted higher than 20 ft. (6.1m)
- Luminaires operate at full intensity until OneButton™ Setup is initiated by the Cree Lighting Configuration Tool
- Daylight harvesting calibration performed automatically during OneButton™ Setup

INTEGRAL WIRELESS COMMUNICATION

- 2.4GHz wireless mesh technology with AES 128-bit encryption
- Self assigns to quietest channel during OneButton™ Setup
- Range:**
 - 30 ft. (9.1m) in typical commercial applications
 - 300 ft. (91.4m) open air without obstructions

- Network:** 250 devices max.
- Space:** 100 devices max. per group
- FCC and IC certifications

LUMINAIRE

- Energy metering with 4% accuracy
- Luminaires operate at full intensity until OneButton™ Setup is initiated by the Cree Lighting Configuration Tool
- 10 year power fail memory of settings
- NOTE:** SmartCast luminaires must be installed on unswitched AC power. Constant power is required to maintain all luminaires on the SmartCast network. If wall control or manual dimming is required, a SmartCast wall control dimmer must be used for manual on, off, and dimming.

DEPLOYMENT

- Please refer to the SmartCast® Deployment Guide at <https://cree.widened.net/s/mvxtfd2pcz/smartcastr-wireless-deployment-guide>

CR Version B Troffer Series Ambient Adjusted Lumen Maintenance ¹					
Ambient	Initial LMF	25K hr Reported ² LMF	50K hr Reported ² LMF	75K hr Estimated ³ LMF	100K hr Estimated ³ LMF
0°C (41°F)	1.04	1.00	0.99	0.97	0.95
5°C (41°F)	1.03	1.00	0.98	0.96	0.94
10°C (50°F)	1.02	0.99	0.97	0.95	0.93
15°C (59°F)	1.02	0.98	0.96	0.95	0.93
20°C (68°F)	1.01	0.98	0.96	0.94	0.92
25°C (77°F)	1.00	0.97	0.95	0.93	0.91
30°C (86°F)	0.99	0.96	0.94	0.93	0.91
35°C (95°F)	0.99	0.95	0.93	0.91	0.90

¹ Lumen maintenance values at 25°C (77°F) are calculated per IES TM-21 based on IES LM-80 report data for the LED package and in-situ luminaire testing. Luminaire ambient temperature factors (LATF) have been applied to all lumen maintenance factors.

² In accordance with IES TM-21, Reported values represent interpolated values based on time durations that are up to 6x the tested duration in the IES LM-80 report for the LED.

³ Estimated values are calculated and represent time durations that exceed the 6x test duration of the LED.

CR14™, CR22™, and CR24™ Architectural LED Troffer - Version B

Delivered Lumens & Electrical Data*														
Product/Size	Lumen Package	Initial Delivered Lumens	Efficacy	System Watts 120-347V	Total Current (A)					EB/GTD Wattage	EB/GT Current (A)			
					120V	208V	240V	277V	347V		120V	208V	240V	277V
CR14/CR24	22L	2,250	132	17	0.16	0.09	0.08	0.07	0.06	20	0.18	0.10	0.09	0.08
	31L	3,140	137	23	0.22	0.12	0.11	0.09	0.08	26	0.24	0.14	0.12	0.10
	40L	4,040	135	30	0.28	0.16	0.14	0.12	0.10	33	0.31	0.18	0.15	0.13
	50L	5,070	133	38	0.33	0.20	0.17	0.15	0.12	41	0.35	0.21	0.18	0.16
CR22	20L	2,030	127	16	0.16	0.09	0.08	0.07	0.06	19	0.18	0.11	0.09	0.08
	32L	3,190	128	25	0.23	0.13	0.11	0.10	0.08	28	0.25	0.15	0.13	0.11

* Lumen and electrical data at 25 °C (77 °F). Actual wattage may differ by +/- 10% when operating between 120-277V or 347V +/- 10%.

Photometry

CR14-B-22L-930-UNV-10V1 BASED ON RESTL TEST REPORT #: PL17011-001A

Luminaire photometry has been conducted in accordance with IES LM-79. IES LM-79 specifies the entire luminaire as the source resulting in a luminaire efficiency of 100%.

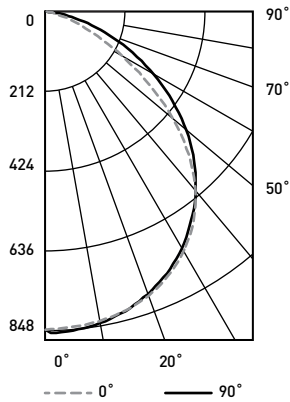

Coefficients Of Utilization – Zonal Cavity Method				
RC %:	80			
RW %:	70	50	30	10
RCR: 0	119	119	119	119
1	110	106	102	98
2	101	93	87	82
3	92	82	75	69
4	85	73	65	59
5	78	66	57	51
6	72	59	51	45
7	67	54	45	40
8	62	49	41	35
9	58	45	37	32
10	55	42	34	29

Effective Floor Cavity Reflectance: 20%

Reference <http://creelighting.com/products/indoor/troffers/cr-series> for detailed photometric data

Average Luminance Table (cd/m²)			
Vertical Angle	Horizontal Angle		
	0°	45°	90°
45°	2,170	2,176	2,099
55°	1,978	1,887	1,620
65°	1,663	1,343	1,005
75°	1,240	715	552
85°	651	369	428

Zonal Lumen Summary			
Zone	Lumens	% Lamp	Luminaire
0-30	661	N/A	30.4%
0-40	1,086	N/A	49.9%
0-60	1,858	N/A	85.5%
0-90	2,174	N/A	100%
0-180	2,174	N/A	100%

Photometry

CR22-B-32L-930-UNV-10V1 BASED ON RESTL TEST REPORT #: PL16975-001B

Luminaire photometry has been conducted in accordance with IES LM-79. IES LM-79 specifies the entire luminaire as the source resulting in a luminaire efficiency of 100%.

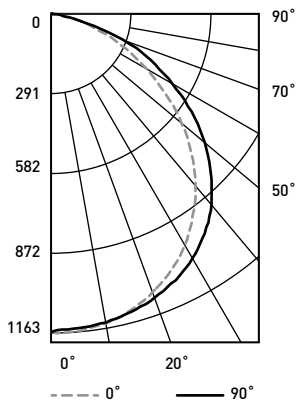

Coefficients Of Utilization – Zonal Cavity Method				
RC %:	80			
RW %:	70	50	30	10
RCR: 0	119	119	119	119
1	110	105	101	98
2	100	92	86	81
3	92	81	74	67
4	84	72	64	57
5	77	65	56	49
6	71	58	50	43
7	66	53	44	38
8	62	48	40	34
9	58	44	36	31
10	54	41	33	28

Effective Floor Cavity Reflectance: 20%

Reference <http://creelighting.com/products/indoor/troffers/cr-series> for detailed photometric data

Average Luminance Table (cd/m²)			
Vertical Angle	Horizontal Angle		
	0°	45°	90°
45°	2,810	3,053	3,195
55°	2,441	2,829	2,986
65°	1,929	2,360	2,604
75°	1,253	1,663	1,420
85°	286	164	136

Zonal Lumen Summary			
Zone	Lumens	% Lamp	Luminaire
0-30	910	N/A	29.0%
0-40	1,497	N/A	47.7%
0-60	2,616	N/A	83.4%
0-90	3,138	N/A	100%
0-180	3,138	N/A	100%

Photometry

CR24-B-40L-930-UNV-10V1 BASED ON RESTL TEST REPORT #: PL16995-001B

Luminaire photometry has been conducted in accordance with IES LM-79. IES LM-79 specifies the entire luminaire as the source resulting in a luminaire efficiency of 100%.

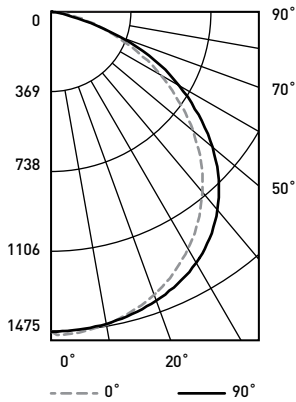

Coefficients Of Utilization – Zonal Cavity Method				
RC %:	80			
RW %:	70	50	30	10
RCR: 0	119	119	119	119
1	110	105	101	97
2	100	92	85	80
3	91	81	73	67
4	83	72	63	56
5	77	64	55	49
6	71	58	49	42
7	66	52	43	37
8	61	47	39	33
9	57	44	35	30
10	53	40	32	27

Effective Floor Cavity Reflectance: 20%

Reference <http://creelighting.com/products/indoor/troffers/cr-series> for detailed photometric data

Average Luminance Table (cd/m²)			
Vertical Angle	Horizontal Angle		
	0°	45°	90°
45°	1,869	1,999	2,090
55°	1,696	1,879	1,957
65°	1,405	1,639	1,687
75°	973	1,165	824
85°	300	73	79

Zonal Lumen Summary			
Zone	Lumens	% Lamp	Luminaire
0-30	1,158	N/A	27.8%
0-40	1,920	N/A	46.1%
0-60	3,422	N/A	82.2%
0-90	4,162	N/A	100%
0-180	4,162	N/A	100%

Application Reference

1x4 & 2x4 Application Reference

Open Space						
Spacing	Lumen Package	Initial Delivered Lumens	Wattage	LPW	w/ft²	Average fc
8 x 8	22L	2,250	17	132	0.26	32
	31L	3,140	23	137	0.35	45
	40L	4,040	30	135	0.45	58
	50L	5,070	38	133	0.57	73
8 x 10	22L	2,250	17	132	0.21	27
	31L	3,140	23	137	0.29	37
	40L	4,040	30	135	0.38	48
	50L	5,070	38	133	0.48	60
10 x 10	22L	2,250	17	132	0.17	21
	31L	3,140	23	137	0.23	30
	40L	4,040	30	135	0.30	39
	50L	5,070	38	133	0.38	48
10 x 12	22L	2,250	17	132	0.14	17
	31L	3,140	23	137	0.18	24
	40L	4,040	30	135	0.24	31
	50L	5,070	38	133	0.30	39

10' ceiling: 80/50/20 reflectances; 2.5' workplane, open room. LLF: 1.0 Initial

Open Space: 50' x 40' x 10

2x2 Application Reference

Open Space						
Spacing	Lumen Package	Initial Delivered Lumens	Wattage	LPW	w/ft²	Average fc
8 x 8	20L	2,030	16	127	0.24	29
	32L	3,190	25	128	0.38	46
8 x 10	20L	2,030	16	127	0.20	24
	32L	3,190	25	128	0.31	38
10 x 10	20L	2,030	16	127	0.16	19
	32L	3,190	25	128	0.25	31
10 x 12	20L	2,030	16	127	0.13	16
	32L	3,190	25	128	0.20	25

10' ceiling: 80/50/20 reflectances; 2.5' workplane, open room. LLF: 1.0 Initial

Open Space: 50' x 40' x 10

CR14

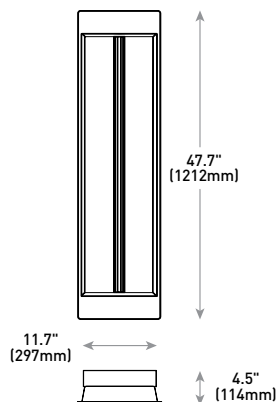

NOTE: Use of Expanded Junction Box will expand the depth to 6.5" (164mm) and Emergency Backup will expand the depth to 4.9" (126mm).

Luminaire	Weight
1x4	12.4 lbs. (5.6kg)

CR22

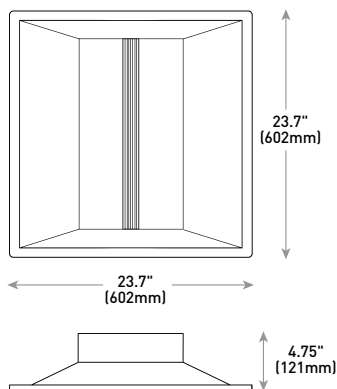

NOTE: Use of Expanded Junction Box will expand the depth to 6.7" (170mm) and Emergency Backup will expand the depth to 5.2" (131mm).

Luminaire	Weight
2x2	8.2 lbs. (3.7kg)

CR14 w/ SC1 Control

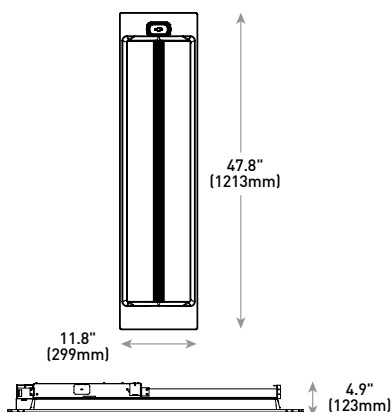

NOTE: Use of Expanded Junction Box will expand the depth to 6.5" (164mm) and Emergency Backup will expand the depth to 4.9" (126mm) and the above ceiling width to 12.3" (311mm).

Luminaire	Weight
1x4	15.4 lbs. (7.0kg)

CR22 w/ SC1 Control

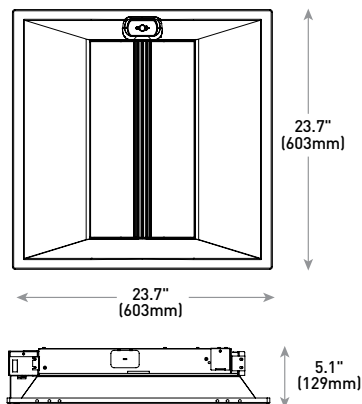

NOTE: Use of Expanded Junction Box will expand the depth to 6.7" (170mm) and Emergency Backup will expand the depth to 5.2" (131mm).

Luminaire	Weight
2x2	11.2 lbs. (5.1kg)

CR24 w/ SC1 Control

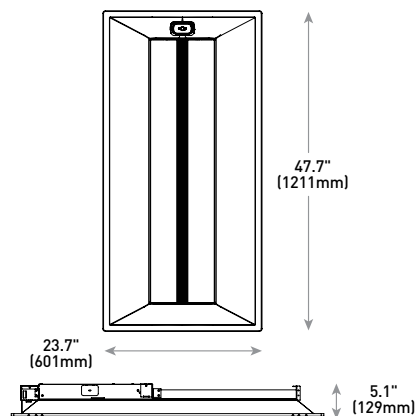

NOTE: Use of Expanded Junction Box will expand the depth to 6.7" (170mm) and Emergency Backup will expand the depth to 5.2" (131mm).

Luminaire	Weight
2x4	21.2 lbs. (9.6kg)

ANSI/IES TM-30-18

4000K, 90 CRI
Based on RESTL TEST #: PL16997-001

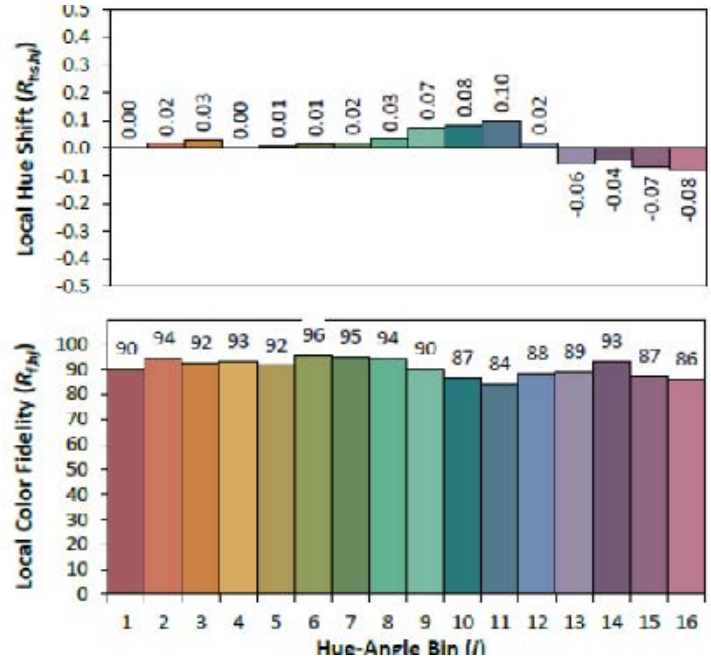
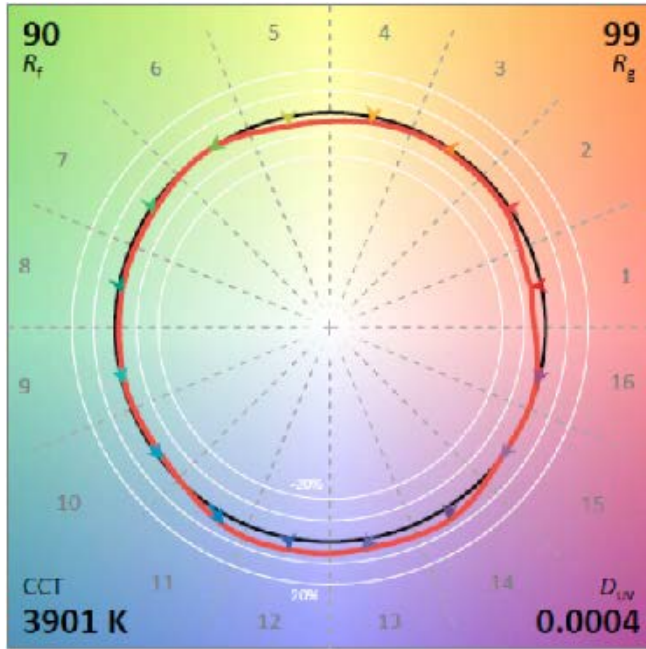

Accessories

Field-Installed			
<p>Adjustable Power Feeds with Cable Support Canopy Kits AC5-18/4-72-PD8-JB - Requires use of surface mount kit</p> <p>Adjustable Cable Support Kits AC5-72-PD8-JB - Requires use of surface mount kit</p> <p>T-Bar Clips for Hunter Douglas® Ceilings CR-HDC - Makes the CR troffers compatible with Armstrong XL, USG DX 1-1/2" or USG 1-5/8" T-grids - Allows fixture to hang 1-1/2" below T-grid to be flush with ceiling tiles - One required per luminaire - Includes 4 clips and 8 screws</p> <p>Drywall Grid Adaptor DGA14-WHT (1x4) DGA22-WHT (2x2) DGA24-WHT (2x4)</p>	<p>Junction Box (5-Pack) EJBCR-5PK - Expanded size junction box for through wiring - Not compatible with surface mount kits</p> <p>6' Flexible Power Whip PW-18/4-06-9T/SS - For use in non-dimming applications only</p> <p>Surface Mount Kit SMK-CR14 (1x4) SMK-CR22 (2x2) SMK-CR24 (2x4) - Not compatible with EJBCR-5PK</p>	<p>SmartCast® Technology Configuration Tool CCT-CWC-1 - One required per project when SC1 control is selected</p> <p>SmartCast® Technology Face Plates CFP-1-WH - Matching face plate, 1-gang, white CFP-2-WH - Matching face plate, 2-gang, white</p> <p>SmartCast® Technology Wireless Dimmer CSC-CWD-UNVN-WH (neutral wire required) CSC-CWD-UNV-WH (no neutral required)</p> <p>SmartCast® Technology Adjustable CCT Wireless Dimmer CSC-CCD-UNVN-WH (neutral wire required) CSC-CCD-UNV-WH (no neutral required) - For use only with luminaires with SmartCast controls and 9ACK - 3000K-5000K adjustable CCT</p> <p>SmartCast® Technology Wireless Switch CSC-CWS-UNVN-WH (neutral wire required) CSC-CWS-UNV-WH (no neutral required)</p> <p>SmartCast® 5-Button Wireless Scene Controller CSC-SC-5B-CWC-WH (w/o text) CSC-SC-5S-CWC-WH (w/scene text) CSC-SC-5C-CWC-WH (w/CCT text) - Available only with 9ACK CSC-SC-5X-CWC-WH (w/custom text)</p>	<p>SmartCast® Technology Wireless Plug Load Controller CPLC-JB-CWC</p> <p>SmartCast® Touchscreen Control CSC-TS-A-BK</p> <p>SmartCast® Wireless Gateway with Wi-Fi CSC-GW-CWC-W - Required with SmartCast Touchscreen Control</p> <p>SmartCast® Wall Plug Power Supply CSC-WPS-120V - For use with SmartCast Wireless Gateway with Wi-Fi</p> <p>SmartCast® Ceiling Plug Power Supply CSC-CPS-120V - For use with SmartCast Wireless Gateway with Wi-Fi</p> <p>SmartCast® 10V Zone Controller CSC-ZC-10V-CWC - Intelligent sensing and control of 0-10V luminaires</p>

© 2023 Cree Lighting, A company of IDEAL INDUSTRIES. All rights reserved. For informational purposes only. Content is subject to change. Patent www.creeighting.com/patents. Cree®, the Cree Lighting logo, TrueWhite®, Cree TrueWhite® and the Cree TrueWhite Technology logo are registered trademarks of Cree, Inc. SmartCast® and the SmartCast Technology logo are registered trademarks, and CR14™, CR22™, and CR24™ are trademarks of Cree Lighting, A company of IDEAL INDUSTRIES. The UL logo is a registered trademark of UL LLC. Lutron®, Lutron EcoSystem®, EcoSystem®, and the Lutron EcoSystem Enabled logo are registered trademarks of Lutron, Inc. Hunter Douglas® is a registered trademark of Hunter Douglas International, N.V. Corporation. The DLC QPL, DLC QPL Premium and the DLC LUNA Logos are the registered and unregistered trademarks of Efficiency Forward, Inc.