

RAIL 6 S6

TUNABLE . RECESSED DRYWALL FLANGELESS . DIRECT

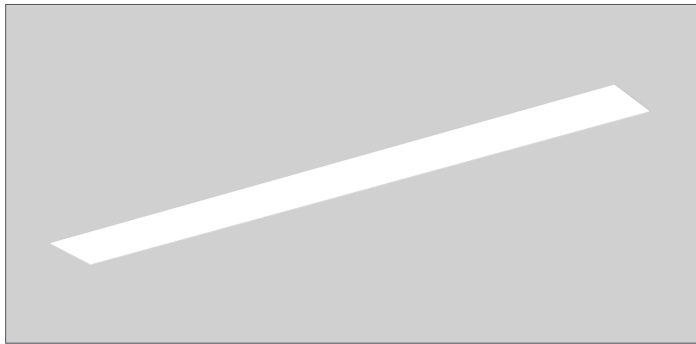

PART #:	
PREP BY:	DATE:
PROJECT:	QTY:
NOTES:	
APPROVAL SIGNATURE:	DATE (DD/MM/YYYY):

PERFORMANCE SUMMARY @ 4000K

	Meta Blanc (MB)	Drop Lens (MD)
	L3	L3
Lumens per foot	80 CRI	Contact factory for Light Level Performance
	90 CRI	
Wattage per foot		
Efficacy (lm/W)	80 CRI	
	90 CRI	
L70 Estimate (h)	> 100,000 hrs	

FEATURES

- Independant control of intensity and correlated color temperature (CCT)
- Allows for scheduled mimicking of daylight color temperatures
- Dim-to-Warm simulates warmer CCT shift as luminaire dims (i.e. like traditional incandescent and halogen lights).

ORDERING LOGIC

Example Part Number: S6-1LTUN-12-MB-W-L31-DF-1-D-90

S6							DF			
1	2	3	4	5	6	7	8	9	10	11
1. SERIES S6	2. COLOR TEMP 1LTUN Tunable White (2700 - 6500K) 1LDW Dim to Warm* (3500 - 2700K) 90 CRI is available under OPTIONS Dim to Warm is not available with integrated sensors. Tunable White and Dim to Warm are available with emergency battery packs connected to the cool color LEDs only.	3. LENGTH 2 2 ft 3 3 ft 4 4 ft 5 5 ft 6 6 ft 7 7 ft 8 8 ft 9 9 ft 10 10 ft 11 11 ft 12 12 ft RA Continuous Rows Replace "A" with length in feet selected on the CONTINUOUS ROWS page	4. OPTICS MB Meta Blanc MD Drop Lens Meta Blanc & Drop Lens: Opal diffuse lens	5. FINISH SA Satin Aluminum W White B Black C Custom Finish Specify RAL:	6. LIGHT LEVEL / DRIVER L1 Select Driver below. L2 Contact factory for Light Level Performance L3 L4	7. CIRCUITRY 1 1 Circuit EM Emergency / Night Light ¹ B Emergency Battery Pack ²	8. MOUNTING DF Recessed Drywall Flangeless	9. VOLTAGE 1 120 V 2 277 V 4 UNV (120 - 277V)	10. CONTROLS / SENSORS _ None (leave space empty) D Daylight Sensor** O Occupancy Sensor** DO Daylight and Occupancy Sensors**	11. OPTIONS 90 90 CRI, High R9 _ None (leave space empty)

PLEASE NOTE	Dim to Warm is not available with integrated sensors. Tunable White and Dim to Warm are available with emergency battery packs connected to the cool color LEDs only.
-------------	--

* Consult factory for alternate options. | ** Controls intensity only (not CCT). | ¹ Each EM pod, by default, has separate wire entry for DIM and CCT control. | ² Battery operates 4ft sections only.

Select Driver:

- Factory option dual 0-10V (Dim & CCT), 1% Dimming
- Lutron T Series EcoSystem, 1% Dimming
- DALI - Factory Option, DT6 Dual Address, 1% Dimming
- DALI - Factory Option, DT8 Single Address Color Control, 1% Dimming
- DALI - EldoLED

WIRING

Emergency / Night Light	Emergency Battery Pack

Luminaire with Integral Driver	
Line Voltage / Control to Luminaire	
Hard Wire	Power Cord
<p>(7) Leads</p>	<p>(18-6)</p>

Luminaire with Remote Driver (BB Box)	
Line Voltage / Control to Remote Driver (BB Box)	
Hard Wire	Power Cord
<p>(7) Leads</p>	<p>(18-6)</p>

Remote Driver (BB Box) to Luminaire	
Hard Wire	Cord
<p>REMOTE DRIVER</p>	<p>(18-5)</p>

CONTINUOUS ROWS

Step 1) Indicate desired quantity of rows under the QTY column

Step 2) ← Pods → If applicable, select pod(s) per row to indicate desired Emergency Lighting/Night Light/Battery Location. If a similar row requires a different Emergency lighting location, please fill out another sheet.

Record drawings for rows not represented here will be sent out upon order.

QTY	Nominal Length	Run Length Overall	Alone / Start Length	Mid Length(s)	End Length	ROWS IN PLAN VIEW
						Rows are for demonstration purposes only and are not to scale.
	4'	1223 [48.1]	4			
	8'	2442 [96.1]	8			
	12'	3662 [144.2]	12			
	16'	4880 [192.1]	8		8	
	20'	6100 [240.2]	12		8	
	24'	7320 [288.2]	12		12	
	28'	8538 [336.1]	8	12	8	
	32'	9758 [384.2]	12	8	12	
	36'	10978 [432.2]	12	12	12	
	40'	12196 [480.2]	12	8, 8	12	
	44'	13416 [528.2]	12	12, 8	12	
	48'	14636 [576.2]	12	12, 12	12	

LEGEND

- Standard (STD) Wire Entry Location
(located 52mm from end on top of fixture)
- Emergency (EM) / Night Light Location
(4 ft sections)
- EM or Battery Wire Entry Location
(located 52mm from end on top of fixture)

EM / Night Light and EM or Battery Wire Entry location in relation to pod selections:

Example 20 ft run

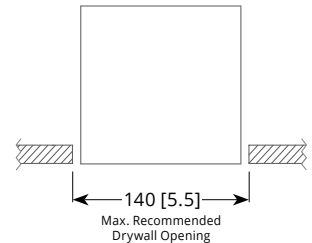

CROSS SECTIONS

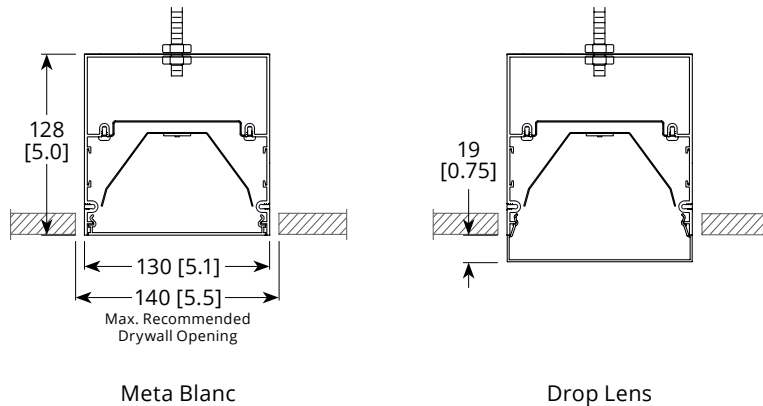

SPECIFICATIONS

Due to the Continuous Improvement Policy at Metalumen, we reserve the right to change our specifications without notice.

Housing: Rigid extruded aluminum body, 2.0mm (0.08") nominal wall thickness. Aluminum end caps.

Optical System: Metalumen luminaires are designed to utilize leading edge LED technology combined with luminaire optimized reflectors and our custom diffusers, resulting in industry leading optical performance.

CRI: 83+ for 3500K, 80 minimum for all

CCTs in standard configurations.

Lumen Maintenance: Minimum 50,000h with TM-21 lumen maintenance of 85% @ 25°C ambient temperature (calculated based on IESNA LM-80-08 LED test data). L70: \geq 100,000hrs.

Finish: Satin aluminum and white are standard finishes. For custom finish, contact factory.

Weight: 1.7 kg/300 mm [3.8 lb/ft]

Mounting: Mounting brackets provided.

Electrical: Factory prewired with easy wire quick connect sections.

Drivers: Metalumen offers 0-10V dimming* as a standard on our entire LED product offering. Dimming range is 1%-100%. Power factor is $>$ 90%. Class 2 rating. Drivers are integral.

Approvals: All components are UL/

CSA/QPS recognized or listed. RoHS compliant. This product is cULus listed. **Environment:** Suitable for dry or damp locations.

**Standard drivers compatible with passive/sinking dimmers. Please contact Metalumen if active/sourcing dimmer support is required.*

WARRANTY

Metalumen will warrant defective luminaires for 5 years from date of purchase. Warranty is valid if luminaire is installed and used according to specification. If defective, Metalumen will send replacement boards or drivers at no cost along with detailed replacement instructions and instructions on how to return defective components to Metalumen.