

# Seem<sup>®</sup> 2

LED - WET LOCATION

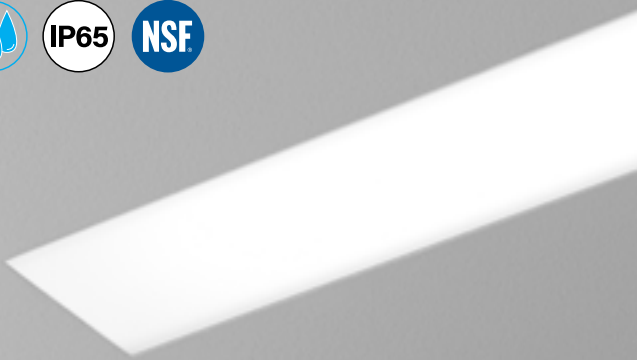

## DIMENSIONAL DATA

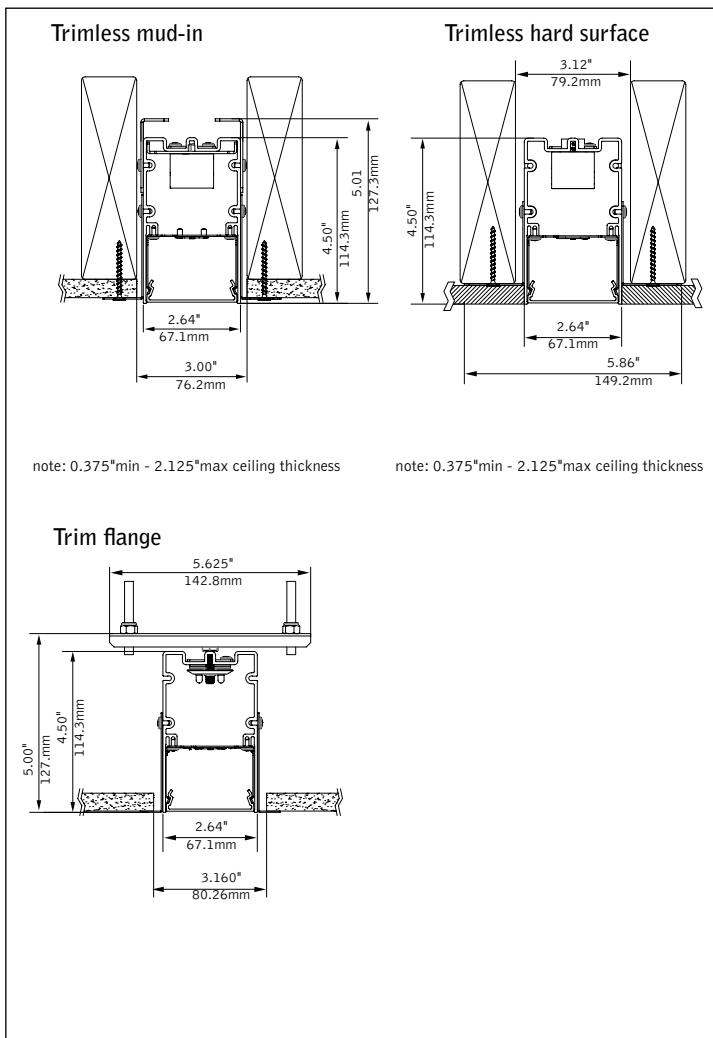

## FEATURES

Narrow extruded aluminum 2.5" aperture recessed slot LED suitable for wet location.

Integrates with ceiling for a clean, unobtrusive aesthetic.

Individual units and continuous runs in 1' increments.

Frosted acrylic lens provides uninterrupted illumination, without pixels or shadows.

LED position and lens material optimized to provide the perfect blend of high performance and visual comfort.

## PERFORMANCE

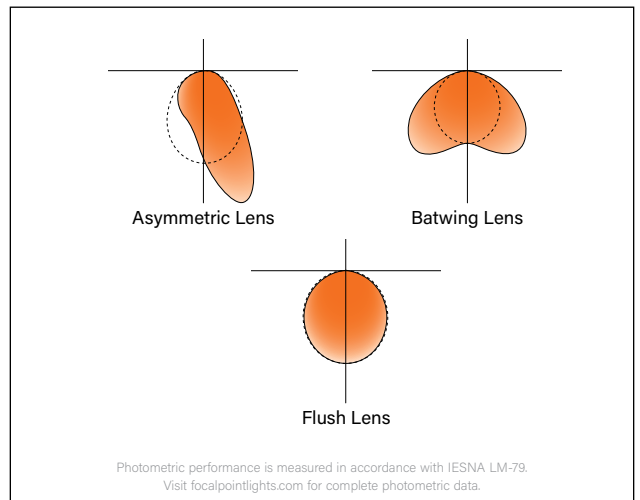

fixture:

project:

### SPECIFICATIONS

#### LED System

Proprietary linear LED module incorporates premium LEDs on a robust platform to achieve excellent thermal management. LEDs are placed to promote a uniform appearance. Available in 3000K, 3500K, 4000K with CRI>80, 3SDCM. LED modules and drivers are replaceable from below.

#### Construction

One piece extruded aluminum housing. 20 Ga. steel end caps. Housing for new construction applications. 2' unit weight: 5.1 lbs., 3' unit weight: 7.6 lbs., 4' unit weight: 10.1 lbs., 5' unit weight: 12.6 lbs.

#### Optic

Reflectors fabricated of 22 Ga. steel finished in High Reflectance White powder coat. Extruded acrylic lens .07" thick with satin finish, up to 8' continuous. .020" thick acrylic lens water shield included for continuous runs.

#### Electrical

Luminaires are pre-wired with factory installed branch circuit wiring and over-molded quick connects. Standard 120-277V constant current driver includes 0-10V analog dimming. Power factor > .9.

#### Emergency Battery

Output - 10 watts for 90 minutes. Maximum mounting height: 17.9ft.

#### Labels

UL and cUL Listed for wet location recessed ceiling applications in indoor and outdoor environments. Lutron Drivers not recommended for outdoor environments below 0°C. IP65 per IEC 60529 ensures that the enclosure is dust-tight and protected against jet streams of water from any direction without any harmful effects.

#### Finish

Polyester powder coat applied over a multi-stage pre-treatment.

#### Lumen Maintenance

Reported: L70 at >61,000 hours                      Calculated: L70 at 385,000 hours  
                  L90 at >61,000 hours                      L90 at 103,000 hours

Derived from EPA TM-21 calculator. Based on typical conditions, consult factory for additional data.

#### Reliability

At Focal Point, our products are designed to stand the test of time. Each luminaire is engineered using superior components, manufactured with the utmost care and rigorously tested. Contact us for reliability data.

#### Warranty

LED system rated for operation in ambient environments up to 35°C. 5-year limited warranty.

### 4' PERFORMANCE CHART

See page 3.

### ORDERING

<b>Luminaire Series</b>	<b>FSM2LWL</b>
Seem 2 LED Wet Location	FSM2LWL
<b>Shielding</b> <small>(Ceiling applications only)</small>	
Asymmetric Lens	AS
Batwing Lens	BW
Flush Lens	FL
<b>Lumen Output</b>	
125 Lumens per foot <small>(4' minimum.)</small>	125LF
250 Lumens per foot	250LF
375 Lumens per foot	375LF
500 Lumens per foot	500LF
625 Lumens per foot	625LF
750 Lumens per foot	750LF
875 Lumens per foot	875LF
1000 Lumens per foot	1000LF
<b>Color Temperature</b>	
3000K, 80+ CRI or 90+ CRI	30K or 930K
3500K, 80+ CRI or 90+ CRI	35K or 935K
4000K, 80+ CRI or 90+ CRI	40K or 940K
<b>Circuits &amp; Zones</b>	
1 Circuit, non-emergency	1C
Consult Ordering Guide on page 3 for multiple circuiting and zoning options	_C_Z_DL
<b>Voltage</b>	
120/277 UNV Volt	UNV
347 volt <small>(LD1 and L11 driver only)</small>	347V
<b>Control System &amp; Dimming Level</b>	
0-10V - 1% Dimming	L11
0-10V - 10% Dimming	LD1
Lutron Hi-Lume EcoSystem (LDE1) - 1% Dimming	LH1
<b>Ceiling Configuration</b>	
Trim Flange Drywall	TF
Mud-in Trimless, 1/2" Drywall	XF1
Mud-in Trimless, 5/8" Drywall	XF2
Mud-in Trimless, any Drywall Thickness	XFF
Non-Drywall Hard Surface	XFN
<b>Factory Options</b> <small>(See Ordering Guide for ordering details for DC, EC, EM &amp; ECD.)</small>	
Chicago Plenum	CP
Daylight Circuit	_DC
Emergency Circuit	_EC
Emergency Battery Pack†	_EM
Emergency Control Device†	_ECD
<small>†(4' minimum.)</small>	
6' New York City Flex Whip	FNY
6' Flex Whip	FW
IP65 Rated <small>(Individual units only, not available with Flex Whip)</small>	IP65
<b>Finish</b>	<b>WH</b>
Matte White Housing	WH
<b>Luminaire Length</b>	<b>ft</b>
Specify luminaire/row length in 1' increments	_ft
<small>(2' minimum, lengths are nominal.)</small>	

#### 4' PERFORMANCE CHART

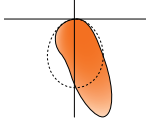
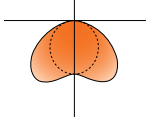
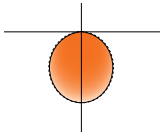
Shielding	Lumens per Foot	Delivered Lumens	Tested System Watts	LPW
Asymmetric Lens 	125LF	561	5.7	99
	250LF	1172	9.6	122
	375LF	1784	13.9	128
	500LF	2390	18.3	130
	625LF	2989	23.7	126
	750LF	3582	28.4	126
	875LF	4167	33.4	125
	1000LF	4745	38.4	124
Batwing Lens 	125LF	538	5.7	95
	250LF	1124	9.6	117
	375LF	1711	13.9	123
	500LF	2293	18.3	125
	625LF	2867	23.7	121
	750LF	3436	28.4	121
	875LF	3997	33.4	120
	1000LF	4551	38.4	119
Flush Lens 	125LF	504	5.7	89
	250LF	1052	9.6	109
	375LF	1601	13.9	115
	500LF	2145	18.3	117
	625LF	2682	23.7	113
	750LF	3214	28.4	113
	875LF	3739	33.4	112
	1000LF	4257	38.4	111

Based on 3500k, 4' lengths. Lumen multiplier: Continuous runs = 0.93 Lumen output may vary +/- 5%. Actual wattage may vary +/- 5%.

# Ordering Guide



Direct Only Linear Circuitry, Zones & Factory Options

## HOW TO USE THIS GUIDE

Fill out the worksheet on the following page to specify your requirements for circuitry, zones, and factory options.

Refer to the run chart for standard run configurations, consult factory for custom configurations.

Complete the Totals / Ordering Codes at the bottom of the worksheet and add to your ordering logic on the cut sheet.

Submit the worksheet along with your order.

TOTAL RUN LENGTH: <u>32ft</u>		JOB NAME: _____			FIXTURE TYPE: _____			
HOUSING SECTION	SECTION LENGTH	SHARED ELECTRICAL FEED, NORMAL POWER			FACTORY OPTIONS			
		SWITCHING CIRCUIT	DIMMING ZONE	DAYLIGHT ZONE	SEPARATE ELECTRICAL FEEDS			EM
					DAYLIGHT CIRCUIT	EMERGENCY CIRCUIT	ECD	
1	8	1C	1Z					1EM
2	8	2C	2Z					
3	8	2C	2Z					
4	8				1DC			
<b>Totals / Ordering Codes</b>		<b>2C</b>	<b>2Z</b>		<b>1DC</b>			<b>1EM</b>

ORDERING: FSM4L-FL-625LF-35K- **2C2Z** -UNV-LD1-G2- **1DC-1EM** -WH-32ft

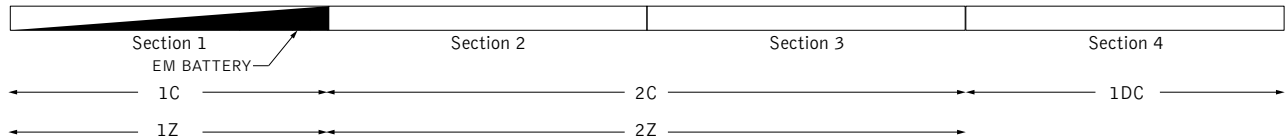

KEY	
<b>C = Switching Circuit</b> Switched Hot / Shared Neutral	<b>DC = Daylight Circuit</b> Switched Hot / Separate Neutral
<b>Z = Dimming Zone</b> Dimming Control Wires	<b>EC = Emergency Circuit</b> Switched Hot / Separate Neutral
<b>DL = Daylight Zone</b> Daylight Dimming Control Wires	<b>EM = Emergency Battery</b> Unswitched Hot / Shared Neutral
	<b>ECD = Emergency Control Device</b> Unswitched Hot / Separate Neutral

## DEFAULTS

- Zones and Factory Options illuminate entire sections from 4' to 8' in length.
- One shared or isolated circuit and zone required per housing section.
- Limit of one EM or ECD per housing section.
- Additional electrical feed required for applications greater than three shared circuits and zones.
- Each DC, EC and ECD require an additional electrical feed.
- ECD not available in the same housing section as EC.
- Longer lead times and additional pricing may apply for custom run configurations.

## CUSTOM LENGTHS

- If partial illumination of emergency or daylight section is required, indicate in ordering guide and add "partial illumination" in Order Notes. Drawing required.
- Engineering validation required, longer lead times may apply.

# Ordering Guide Worksheet

Linear Circuitry, Zones & Factory Options



FOCAL POINT®

TOTAL RUN LENGTH: _____		JOB NAME: _____			FIXTURE TYPE: _____			
HOUSING SECTION	SECTION LENGTH	SHARED ELECTRICAL FEED, NORMAL POWER			FACTORY OPTIONS			EM
		SWITCHING CIRCUIT	DIMMING ZONE	DAYLIGHT ZONE	SEPARATE ELECTRICAL FEEDS			
DAYLIGHT CIRCUIT	EMERGENCY CIRCUIT				ECD			
1								
2								
3								
4								
5								
6								
7								
8								
9								
10								
11								
12								
13								
14								
15								
16								
17								
18								
19								
20								
<b>Totals / Ordering Codes</b>								

WORKSHEET

Combine to create Circuits & Zones ordering code

Enter as individual Factory Options

## RUN CHART

Run length (ft)	Housing Configuration Section Lengths	Run length (ft)	Housing Configuration Section Lengths	Run length (ft)	Housing Configuration Section Lengths	Run length (ft)	Housing Configuration Section Lengths
9	5 + 4	21	8 + 8 + 5	33	8 + 8 + 8 + 5 + 4	45	8 + 8 + 8 + 8 + 8 + 5
10	6 + 4	22	8 + 8 + 6	34	8 + 8 + 8 + 6 + 4	46	8 + 8 + 8 + 8 + 8 + 6
11	7 + 4	23	8 + 8 + 7	35	8 + 8 + 8 + 7 + 4	47	8 + 8 + 8 + 8 + 8 + 7
12	8 + 4	24	8 + 8 + 8	36	8 + 8 + 8 + 8 + 4	48	8 + 8 + 8 + 8 + 8 + 8
13	8 + 5	25	8 + 8 + 5 + 4	37	8 + 8 + 8 + 8 + 5		
14	8 + 6	26	8 + 8 + 6 + 4	38	8 + 8 + 8 + 8 + 6		
15	8 + 7	27	8 + 8 + 7 + 4	39	8 + 8 + 8 + 8 + 7		
16	8 + 8	28	8 + 8 + 8 + 4	40	8 + 8 + 8 + 8 + 8		
17	8 + 5 + 4	29	8 + 8 + 8 + 5	41	8 + 8 + 8 + 8 + 5 + 4		
18	8 + 6 + 4	30	8 + 8 + 8 + 6	42	8 + 8 + 8 + 8 + 6 + 4		
19	8 + 7 + 4	31	8 + 8 + 8 + 7	43	8 + 8 + 8 + 8 + 7 + 4		
20	8 + 8 + 4	32	8 + 8 + 8 + 8	44	8 + 8 + 8 + 8 + 8 + 4		

Standard run configurations, consult factory for custom configurations.