

UVT-10002

Light Linear VT 1 Single Side Bollard

52w LED
5287 Lumens

IP65
Suitable for wet locations

IK08
Impact Resistant [Vandal Resistant]

Weight - 19.7 lbs

Construction

Aluminum
Less than 0.1% copper content - Marine Grade 6060 extruded & LM6 Aluminum High Pressure die casting provides excellent mechanical strength, clean detailed product lines and excellent heat dissipation.

Pre paint
8 step decrease and phosphate process that includes deoxidizing and etching as well as a zinc and nickel phosphate process before product painting.

Memory Retentive -Silicon Gasket
Provided with special injection molded "fit for purpose" long life high temperature memory retentive silicon gaskets. Maintains the gaskets exact profile and seal over years of use and compression.

Thermal management
LM6 Aluminum is used for its excellent mechanical strength and thermal dissipation properties in low and high ambient temperatures. The superior thermal heat sink design by Ligman used in conjunction with the driver, controls thermals below critical temperature range to ensure maximum luminous flux output, as well as providing long LED service life and ensuring less than 10% lumen depreciation at 50,000 hours.

Surge Suppression
Standard 10kv surge suppressor provided with all fixtures.

BUG Rating
Contact Factory

Finishing
All Ligman products go through an extensive finishing process that includes fettling to improve paint adherence.

Paint
UV Stabilized 4.9Mil thick powder coat paint and baked at 200 Deg C. This process ensures that Ligman products can withstand harsh environments. Rated for use in natatoriums.

Inspired by Nature Finishes
The Inspired by nature Finishing is a unique system of decorative powder coating. Our metal decoration process can easily transform the appearance of metal or aluminum product into a wood grain finish.

This patented technology enables the simulation of wood grain, and even marble or granite finish through the use of decorative powder coating.

The wood grain finish is so realistic that it's almost undistinguishable from real wood, even from a close visual inspection. The system of coating permeates the entire thickness of the coat and as a result, the coating cannot be removed by normal rubbing, chipping, or scratching.

The Coating Process
After pre-treatment the prepared parts are powder coated with a specially formulated polyurethane powder. This powder provides protection against wear, abrasion, impact and corrosion and acts as the relief base color for the finalized metal decoration.

The component is then wrapped with a sheet of non-porous film with the selected decoration pattern printed on it using special high temperature inks.

This printed film transfer is vacuum-sealed to the surface for a complete thermo print and then transferred into a customized oven. The oven transforms the ink into different forms within the paint layer before it becomes solid. Finally, the film is removed, and a vivid timber look on aluminum remains.

Wood grain coating can create beautiful wood-looking products of any sort. There are over 300 combinations of designs currently in use. Wood grains can be made with different colors, designs, etc.

Our powder coatings are certified for indoor and outdoor applications and are backed by a comprehensive warranty. These coatings rise to the highest conceivable standard of performance excellence and design innovation.

- Added Benefits**
- Resistance to salt-acid rain, accelerated aging
 - Boiling water, lime and condensed water resistant
 - Anti-Graffiti, Anti-Slip, Anti-Microbial, Anti-Scratch
 - Super durable (UV resistant)
 - TGIC free (non-toxic)

Hardware
Provided Hardware is Marine grade 316 Stainless steel.

Anti Seize Screw Holes
Tapped holes are infused with a special anti seize compound designed to prevent seizure of threaded connections, due to electrolysis from heat, corrosive atmospheres and moisture.

Crystal Clear Low Iron Glass Lens
Provided with tempered, impact resistant crystal clear low iron glass ensuring no green glass tinge.

Optics & LED
Precise optic design provides exceptional light control and precise distribution of light.
LED CRI > 80

Lumen - Maintenance Life
L80 /B10 at 50,000 hours (This means that at least 90% of the LED still achieve 80% of their original flux)

Area distribution vertical optical bollards.
Ground-breaking potent asymmetric light distribution performance from a vertical form-factor.

Light Linear VT Bollard is an elegant minimalistic bollard that is suitable for both modern and classic architecture. Ideal for creating visual guidance with exceptional visual comfort. The dual sealed optical chamber with integrated heat sinks houses a range of field interchangeable optically controlled LED's, providing Type II, III, IV & V distribution, as well as variations of this for precise light distribution requirements.

An example of this, is using a combination of Type II and Type IV distribution optics inside the same fixture.

The sleek and minimalistic shape provides distinctive lighting effects by night and decorative urban effect during the day. Suitable for use in pedestrian precincts, building surrounds, shopping centers, squares, parks and parking lots. This product range is complemented with high performance optics in the area light and wall mounted luminaires, to provide a consistent range of design aesthetics for the project. See website for more information. Bollards can be provided with GFCI boxes positioned to specific heights specified by the customer. Internal house side shields are available as an option.

Security Bollard:
The Light Linear Bollard is available as a traffic rated security bollard. This optional design includes a 1/4" wall thickness galvanized steel security pole with 2 1" galvanized cross support rods that are embedded into concrete. This security bollard provides restraint of vehicular traffic in unauthorized areas. Impact calculations shows this bollard will stop a 5,500lb/2.75 tons vehicle, travelling at 30mph. The galvanized pole must be filled with concrete up to the waterproof driver housing to provide a solid concrete barrier.

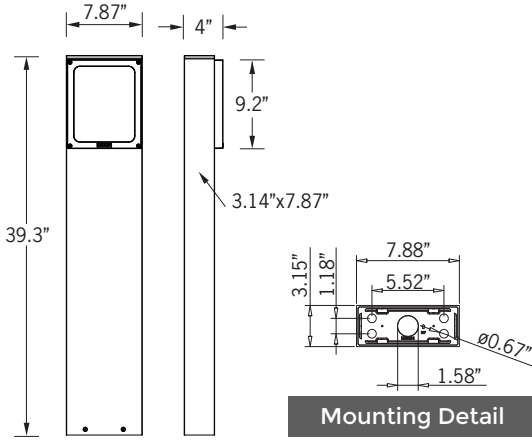

Ligman's micro Variable Optical System provides the ability to interchange, mix & rotate optics to provide specific light distributions for optimized spacing and uniformity.

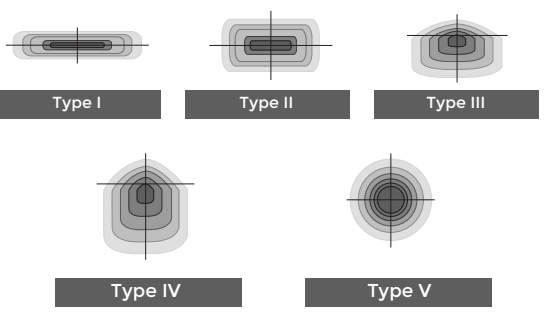

The variable optic system allows for the designer to create hybrid distributions for precise lighting requirements.

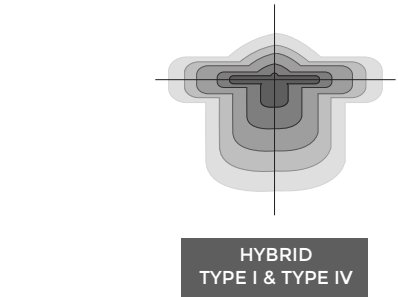

Additional Options (Consult Factory For Pricing)

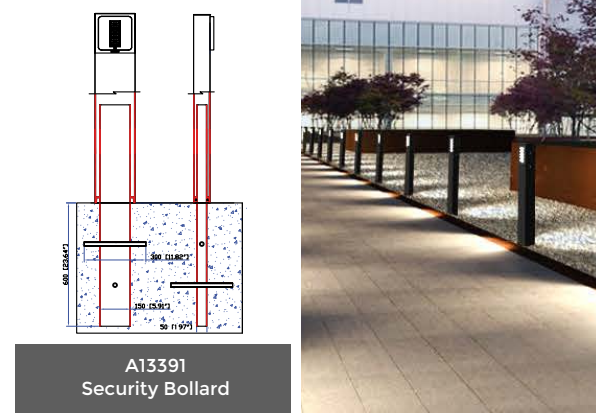

RGBW or Static Color Laser Cut Lettering, Logos & Designs



UVT-10002

Light Linear VT 1 Single Side Bollard

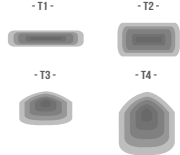

PROJECT	<input type="text"/>	DATE	<input type="text"/>
QUANTITY	<input type="text"/>	TYPE	<input type="text"/>
NOTE	<input type="text"/>		

ORDERING EXAMPLE || UVT - 10002 - 52w - T2 - W30 - 02 - 120/277v - Options

UVT-10002	<input type="text"/>	<input type="text"/>	<input type="text"/>	<input type="text"/>	<input type="text"/>
	LAMP	BEAM	LED COLOR	FINISH COLOR	VOLTAGE
	52w LED 5287 Lumens	T1 - Type I Distribution T2 - Type II Distribution T3 - Type III Distribution T4 - Type IV Distribution 	W27 - 2700K W30 - 3000K W35 - 3500K W40 - 4000K	01 - BLACK RAL 9011 02 - DARK GREY RAL 7043 03 - WHITE RAL 9003 04 - METALLIC SILVER RAL 9006 05 - MATTE SILVER RAL 9006 06 - LIGMAN BRONZE 07 - CUSTOM RAL 	120/277v Other - Specify

<input type="text"/>	<input type="text"/>	<input type="text"/>
----------------------	----------------------	----------------------

ADDITIONAL OPTIONS

- | | | |
|------------------------|----------------------------|----------------------------------|
| NAT - Natatorium Rated | HGT- Custom Bollard Height | WLC - Wireless Lighting Controls |
| F - Frosted Lens | HSS - House Side Shield | UL - Unlit Bollard |
| GFCI - GFCI Box | A13391 - Security Bollard | AMB - Turtle Friendly Amber LED |
| DIM - 0-10v Dimming | EMG - Emergency Pack | |

- INSPIRED BY NATURE FINISHES**
- SW01 - OAK FINISH
 - SW02 - WALNUT FINISH
 - SW03- PINE FINISH
 - DF - DOUGLAS FIR FINISH
 - CW - CHERRY WOOD FINISH
 - NW - NATIONAL WALNUT FINISH
 - SU01 - CONCRETE FINISH
 - SU02 - SOFTSCAPE FINISH
 - SU03 - STONE FINISH
 - SU04 - CORTEN FINISH

THERE IS AN ADDITIONAL COST FOR THESE FINISHES

LASER CUT LETTERING (Cannot be used in conjunction with security bollard)

- RGBW - Color Changing RGBW
- SC - Static Color (Choose Color e.g Red, Blue etc.)

WORDS FRONT	WORDS BACK
<input type="text"/>	<input type="text"/>

CONSULT FACTORY FOR CUSTOM DESIGNS, LOGOS AND OTHER SPECIAL REQUIREMENTS
FACTORY DRAWINGS WILL BE PROVIDED PRIOR TO PRODUCTION

More Custom Finishes Available Upon Request

Consult factory for pricing and lead times



Light Linear VT Product Family



Light Linear VT 1

- UVT-10001-27w-2834lm
- UVT-10002-52w-5287lm



Light Linear VT 2

- UVT-10011-2x27w-2x2834lm
- UVT-10012-2x52w-2x5287lm



Light Linear VT 3

- UVT-20001-56w-4762lm
- UVT-20011-2x56w-2x4762lm



Light Linear VT 4

- UVT-20003-107w-9405lm
- UVT-20004-155w-12645lm



Light Linear VT 5

- UVT-20021-56w-4762lm
- UVT-20022-81w-6429lm



Light Linear VT 6

- UVT-20023-107w-9405lm
- UVT-20024-155w-12645lm