

# AA-56 8" Scroll

ARMS

Sample	AA-56	S	4	B	P	BBT					
Ordering	<input type="text"/>	/	<input type="text"/>	/	<input type="text"/>	/	<input type="text"/>	/	<input type="text"/>	/	<input type="text"/>
	<b>A</b>	<b>B</b>	<b>C</b>	<b>D</b>	<b>E</b>	<b>F</b>					

### DETAILS

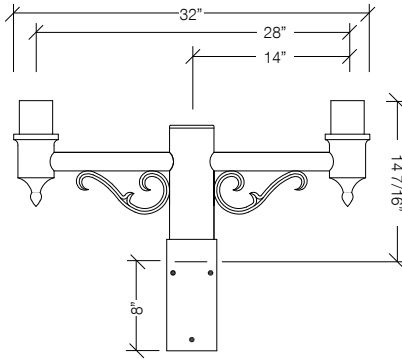

### WALL BRACKET DETAILS

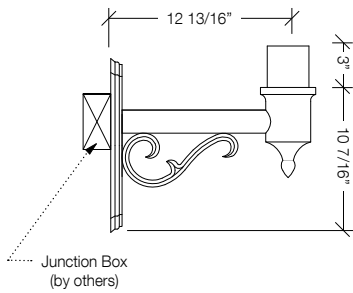

### WALL PLATE DETAILS

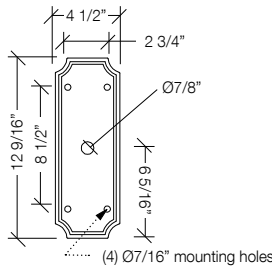

Due to our continued efforts to improve our products, product specifications are subject to change without notice.

### A. MODEL

**AA-56** 8" Scroll

### B. POST SHAFT PROFILE

**W** wall mount  
**S** smooth  
**F** fluted

### C. POST SHAFT DIAMETER

**4** 4"  
**5** 5"  
**6** 6"

**OTHER** \_\_\_\_\_

### D. ARRANGEMENT

\_\_\_\_\_ see arrangement table below

### E. LUMINAIRE MOUNTING

**P** pendant  
**T** tenon

### F. COLOR

**BBT** basic black textured  
**BMT** black matte textured  
**WHT** white textured  
**MBT** metallic bronze textured  
**BZT** bronze textured  
**DBT** dark bronze textured  
**GYS** gray smooth  
**DPS** dark platinum smooth  
**GNT** green textured  
**MST** metallic silver textured  
**MTT** metallic titanium textured  
**OWI** old world iron  
**RAL** \_\_\_\_\_

**Construction:** All cast aluminum parts shall be low copper alloy A356. All extruded aluminum parts shall be alloy 6061-T6, 6063-T5 or equal.

**EPA (effective projected area):** EPA is de-fined as (projected surface area X drag factor) and measured in ft<sup>2</sup>. Allowable post, luminaire arm, luminaire and accessory EPAs are derived from the most current published AASHTO (American Association of State Highway and Transportation Officials) standard, currently AASHTO 2001 (50yr design life). Customer assumes all responsibility for selecting the appropriate post for installation (consult factory for assistance). Luminaire arm, luminaire and accessory EPA must be equal to or less than allowable EPA of post. Consult a professional engineer for compliance with local codes and standards.

**Fasteners:** All fasteners shall be Corrosion Resistant. When tamper resistant fasteners are required, spanner HD (snake eye) style shall be provided (special tool required, available at additional cost).

**Finish:** Finish shall be a Beacote V polyester powder-coat electro-statically applied and thermocured. Beacote V finish shall consist of a five stage iron phosphate chemical pretreatment regimen with a polymer primer sealer, oven dry off, and top coated with a thermoset super TGIC polyester powder coat finish. The finish shall meet the AAMA 605.2 performance specification which includes passing a 3000 hour salt spray test for corrosion resistance and resists cracking or loss of adhesion per ASTM D522 and resists surface impacts of up to 160 inch-pound.

**Limited Warranty:** Beacon Products warrants its products, to the original purchaser, against defects in materials and workmanship for proper usage for a period of 5 years after date of production, when properly installed, maintained and appropriately specified.

		arrangement (EPA index ft <sup>2</sup> / weight (lbs))									
shaft Ø		A	B	C	D	E	F	G	H	I	J
wall	weight	10	-	-	-	-	-	-	-	-	-
Ø4"	EPA	-	.63	.85	.90	1.4	1.8	1.8	1.9	2.4	2.4
	weight	-	10	15	16	15	20	21	20	25	26
Ø5"	EPA	-	.73	.95	1.0	1.5	1.9	1.9	2.0	2.5	2.5
	weight	-	12	17	18	17	22	23	22	27	28
Ø6"	EPA	-	.83	1.05	-	1.6	2.0	2.0	2.1	2.6	2.6
	weight	-	15	20	21	20	25	26	25	30	31