



WMA37

1. ARM

2. COLOR

1. ARM

WMA37 (Weight: 12 lbs.)

2. COLOR

WH Arctic White	MDB Bronze Metallic
BL Black	VBU Verde Blue
BLT Matte Black	CRT Corten
DB Dark Bronze	MAL Matte Aluminum
DGN Dark Green	MG Medium Grey
TT Titanium	AGN Antique Green
WDB Weathered Bronze	LG Light Grey
	RAL Premium Color
	CUSTOM * * Contact Factory

DIMENSIONS

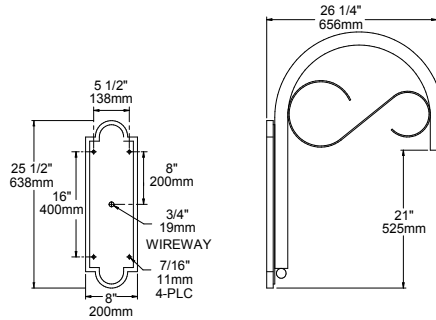

Note: Back plate is welded to the arm.

WMA37

SPECIFICATIONS

The arm shall be of one piece unitized aluminum construction, fully welded and assembled. The back plate shall be one piece cast aluminum. The arm shall be prewired with a quick connector for easy installation.

The arm shall have a cast aluminum fitter welded to the top of the arm(s) for attaching the fixture. The fixture shall be mounted with three stainless steel bolts through the top of the arm fitter into the fixture. The attachment point shall have a silicone pad for sealing the fixture to arm connection.

Mounting hardware and J-box by others.

JOB _____
 TYPE _____
 NOTES _____