

# WMA39– Period Wall Mount Arm

TYPE



WMA39

1. ARM

2. COLOR

## 1. ARM

WMA39 (Weight: 14 lbs.)

## 2. COLOR

|                      |                            |
|----------------------|----------------------------|
| WH Arctic White      | MDB Bronze Metallic        |
| BL Black             | VBU Verde Blue             |
| BLT Matte Black      | CRT Corten                 |
| DB Dark Bronze       | MAL Matte Aluminum         |
| DGN Dark Green       | MG Medium Grey             |
| TT Titanium          | AGN Antique Green          |
| WDB Weathered Bronze | LG Light Grey              |
|                      | RAL Premium Color          |
|                      | CUSTOM * * Contact Factory |

## DIMENSIONS

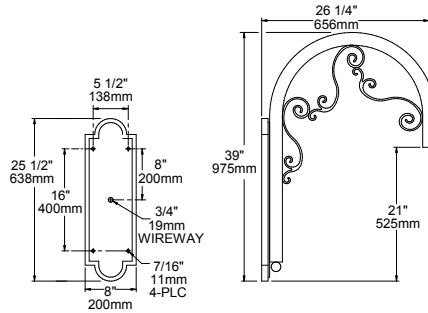

Note: Back plate is welded to the arm.

WMA39

## SPECIFICATIONS

The arm shall be of one piece unitized aluminum construction, fully welded and assembled. The back plate shall be one piece cast aluminum. The arm shall be prewired with a quick connector for easy installation.

The arm shall have a cast aluminum fitter welded to the top of the arm(s) for attaching the fixture. The fixture shall be mounted with three stainless steel bolts through the top of the arm fitter into the fixture. The attachment point shall have a silicone pad for sealing the fixture to arm connection.

Mounting hardware and J-box by others.

JOB \_\_\_\_\_  
 TYPE \_\_\_\_\_  
 NOTES \_\_\_\_\_

