

Stencil® Surface | Surface - Linear - Flush

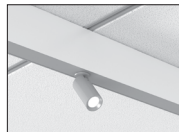

Accent regular shown

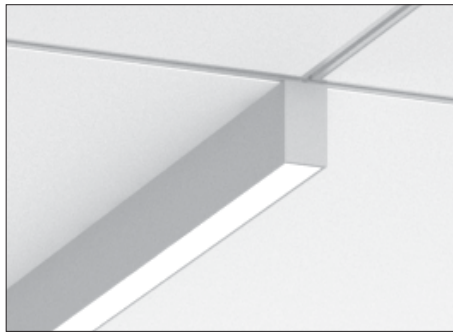
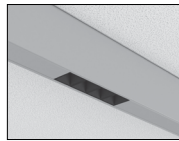

MikroLite 1.0 shown

Single shielding only. See forms spec sheet for combined shielding

Project _____

Type _____

Notes _____

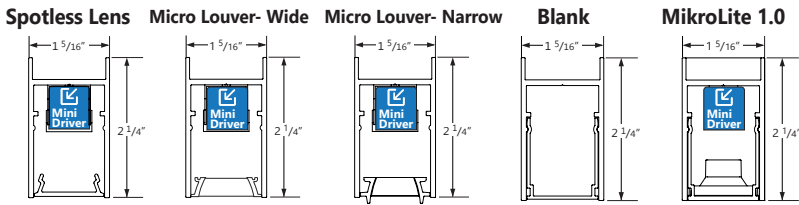

See page 4 for Accent section views

PERFORMANCE PER LINEAR FOOT AT 3500K AT 80 CRI

	NOMINAL LUMEN OUTPUT	INPUT WATTS*	EFFICACY
SO lens Option only	200 lm/ft	2.3 W/ft	88 lm/W
	300 lm/ft	3.15 W/ft	95 lm/W
	400 lm/ft	4.1 W/ft	98 lm/W
Micro louver Option only	200 lm/ft	3.2 W/ft	71 lm/W
	300 lm/ft	4.1 W/ft	74 lm/W
	450 lm/ft	6.1 W/ft	74 lm/W
	600 lm/ft	8.1 W/ft	75 lm/W

* Based on a 4 foot luminaire using one driver
Please consult factory for custom lumen output and wattage.

Ordering Guide

STSLF	PRODUCT ID	LENGTH	SHIELDING	NOM. LUMENS/FT DOWN	CRI	COLOR TEMP.		
STSLF	Stencil Surface Linear - Flush	2 2' *	SO spotless lens	200 200 lm/ft	80 80 CRI	27 2700 K		
		3 3'	MLWB micro louver wide- black*	300 300 lm/ft	90 90 CRI	30 3000 K		
		4 4'	MLNB micro louver narrow - black*	400 400 lm/ft		35 3500 K		
		5 5'	MLWG micro louver wide - grey*	200 200 lm/ft	micro louver option only	40 4000 K		
		6 6'	MLNG micro louver narrow - grey*	300 300 lm/ft				
		8 8'	B blank**	450 450 lm/ft				
			(L) system run		600 600 lm/ft	NA not applicable	Blank option only	
		* 2' sections are NOT available with micro louver optic. Lit segments are available in 1' increments. Lengths suitable for 30x30 grid are available, please consult factory for more information.			Single shielding only. See forms spec sheet for combined shielding. For combined shielding see forms spec sheet (STSF). * See more details on page 4. **Choose for accent only or MikroLite only.		Applies to all downlight segments.	

FINISH	VOLTAGE	DRIVER	CIRCUITS	MOUNTING / SUSPENSION	BATTERY - REMOTE (OPT.)	CUSTOM (OPT.)
AP aluminum paint	120 120 V	MD integral mini driver	1 1 circuit	SB9 surface TB 9/16	B(#) remote battery pack	C custom
W white	277 277 V	0-10V dimming (1%)*	2 2 circuits	SB15 surface TB 15/16		
BLK black	347 347 V *	POE(#) POE drivers**	+E(#) emergency circuit *	SG9 surface TG 9/16		
C custom	UNV universal		+NL(#) night light circuit	SG15 surface TG 15/16		
	DC low voltage**			SBS surface screw slot t-bar		
				S surface drywall ceiling		
				*SC surface solid ceiling		
* Consult factory ** Only available with POE drivers.		* Only integral 0-10V mini driver available ** Specify system	* Specify quantity	Specify length * Please consult factory for power feed options available for your ceiling type and application.	Remote only Not available with 347V Please consult factory	Please specify

Ordering Guide- MikroLite and Accent (Optional)

MIKROLITE - MKL(#, Beam Angles, Cell Finish)			ACCENT - AC(#, Option, Beam, Finish) or ACH(#, Option, Beam, Finish)			
MIKROLITE MODULE QTY.	BEAM ANGLES	CELL FINISH	ACCENT QUANTITY	ACCENT OPTIONS	BEAM	ACCENT FINISH
(#) MikroLite module quantity	MKL35 35 deg MKL20 20 deg	GR gray BLK black	AC(#) accent quantity ACH(#) accent quantity on hub	R regular S snoot	AC20 20 deg AC35 35 deg	AP aluminum paint W white BLK black
Single shielding only. See forms spec sheet for combined shielding; 1 module contains 4 MikroLites; Module length is 4". 500 lm/module See page 4 for more information.			Only available in 500 lumens with 0-10V dimming (5%). Minimum spacing between Accents is 4". Accent provided on blank section by default (min length 3"). See page 5 for more information.		See page 4 for more information.	

● SEGMENT LENGTHS AND MOUNTING POINTS

Flat End Caps					
Segment length		Extrusion	Mounting Distance from edge	Between mounting points	Overall length
Feet	Inches	Inches	Inches	Inches	Inches
2	24	24.188	5.5	13.188	24.488
2.5	30	30.000	5.5	19.000	30.300
3	36	36.000	5.5	25.000	36.300
4	48	48.000	5.5	37.000	48.300
5	60	60.000	5.5	49.000	60.300
6	72	72.000	5.5	61.000	72.300
7	84	84.000	5.5	73.000	84.300
7.5	90	90.000	5.5	79.000	90.300
8	96	96.000	5.5	85.000	96.300

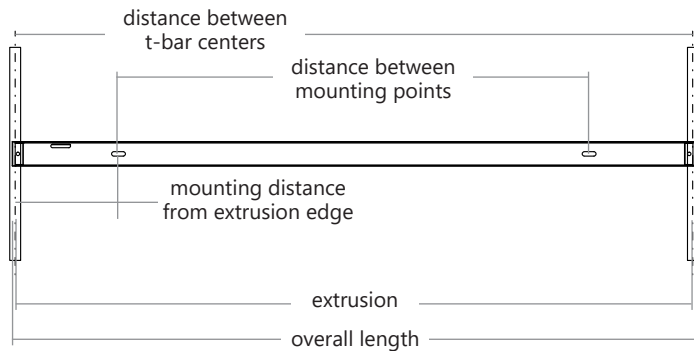

● SURFACE MOUNTING OPTIONS

DRYWALL CEILING

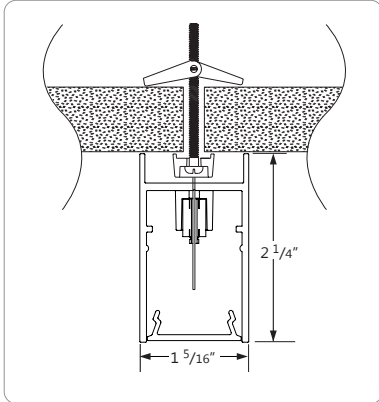

S SURFACE DRYWALL CEILING

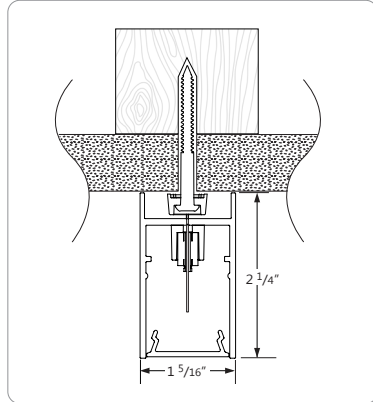

SC SURFACE DRYWALL THROUGH STUD

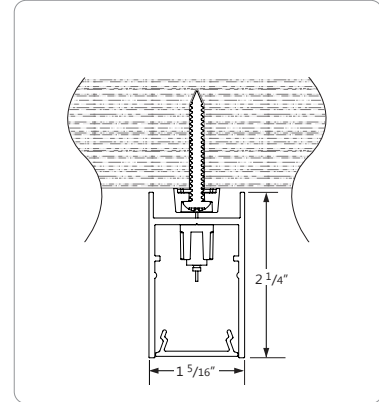

SC SURFACE SOLID CEILING

T-BAR CEILING

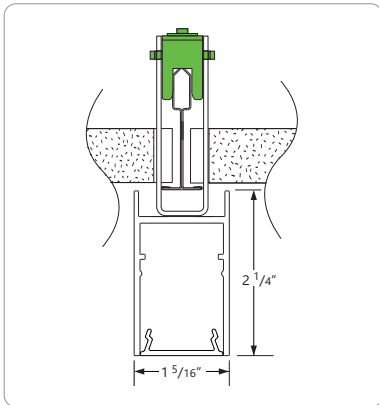

SB9 SURFACE 9/16" T-BAR - ON-GRID

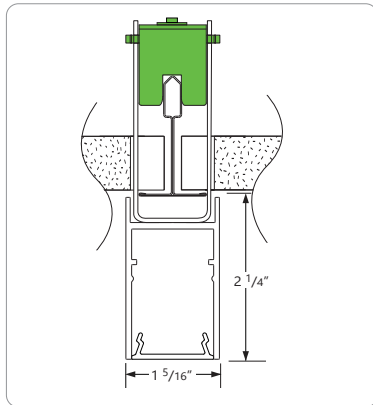

SB15 SURFACE 15/16" T-BAR - ON-GRID

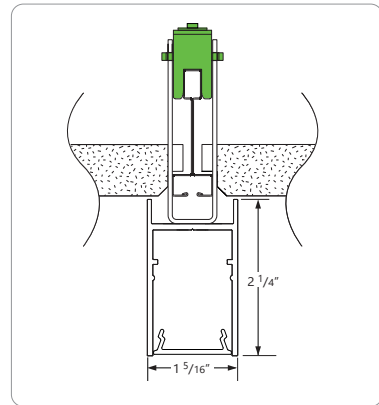

SBS SURFACE SCREW SLOT T-BAR

TEGULAR CEILING

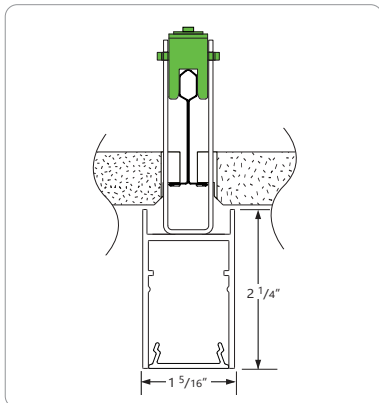

SG9 SURFACE TEGULAR 9/16 - ON-GRID

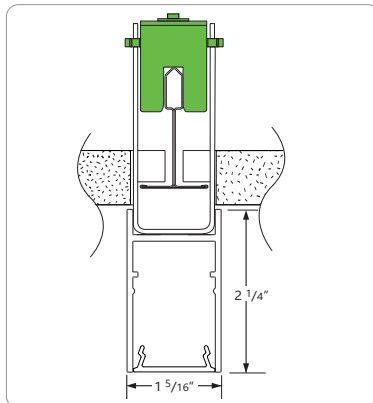

SG15 SURFACE TEGULAR 15/16 - ON-GRID

T-BAR AND TEGULAR CEILING

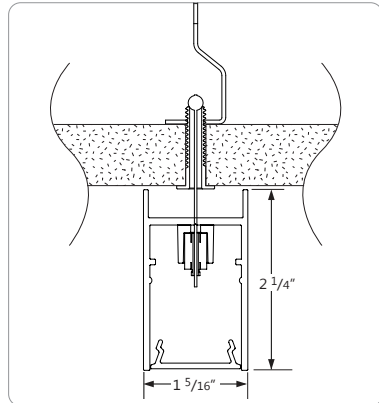

SG9/SG15 SURFACE TEGULAR / T-BAR - OFF-GRID
SB9/SB15

i Shown with spotless lens shielding option.

Stencil® Surface | Surface - Linear - Flush

● LED SYSTEM

CRI	Minimum 80 or 90 color rendering index
CCT	Choice of 2700K, 3000K, 3500K and 4000K color temperature with a great color consistency (within 3.0-step MacAdam ellipse).
LED life	Minimum 50,000h with 85% of lumen maintenance in 25°C ambient temperature, in compliance with IES LM-80 testing measurements.
Thermal Management	Aluminum housing acting as the heat sink to maximize life.
Performance	Up to 108 lm/W.

● CONSTRUCTION

Housing	Extruded aluminum (0.070" nominal)
End Cap+ Joiner	Die cast aluminum
Reflectors	Extruded acrylic
Lenses	Extruded acrylic
Suspension	1/32" Aircraft cable
Cable Grips	Quick Connecting / Release

● ELECTRICAL

Mini driver	STENCIL SURFACE features integral mini driver technology. 0-10V 1% dimming standard. The integral mini driver is the only driver available.
Power over Ethernet POE drivers* (consult factory for more information)	MOLEX IGOR O - Other (Consult factory)
Emergency	Remote emergency battery pack or emergency circuit optional.
Input Voltage	120V, 277V, UNV, 347V

i Incorporating these components may have limitations or affect the length of the luminaire, please contact factory for more details.

● WARRANTY

Axis Lighting will warrant defective LEDs, boards, and drivers for 5 years from date of purchase. Warranty is valid if luminaire is installed and used according to specifications. If defective, Axis will send replacement boards or drivers at no cost along with detailed replacement instructions and instructions on how to return defective components to Axis.

● APPROVALS

Certified to UL and CSA standards  Suitable for damp locations.

● STENCIL SURFACE SEGMENTS

STENCIL SURFACE lit segments are available in lengths of 2' to 8' in one foot increments. Unlit blank segments are available in any length from 7" to 8". Segments exceeding 8' in length are comprised of a combination of lengths to be assembled on site with an Inline Hub. Minimum blank segment length for one Accent is 3'.

For more information on systems and joining, please refer to the STENCIL SURFACE installation sheets available for download at www.axislighting.com.

● LIGHT GUIDE

High precision light guide made of PMMA material, allows distribution of controlled light in all 3-dimensions to put light on both vertical and horizontal planes within the space. Patented lightguide design featuring molecular optics and precision-coupled optic components yield a high efficiency luminaire. In-plane mixing maximizes color uniformity while light emitting area is uniform and diffuse without 'head lighting' from the LED's.

● FINISH

Powder coated and custom finishes are also available.

● MICRO LOUVER OPTIONS

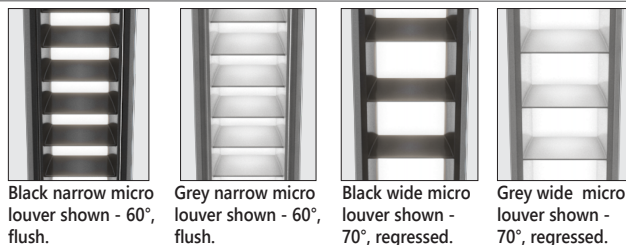

● STENCIL SURFACE WITH MIKROLITE 1.0

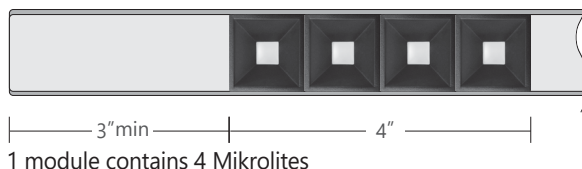

● ACCENT OPTIONS

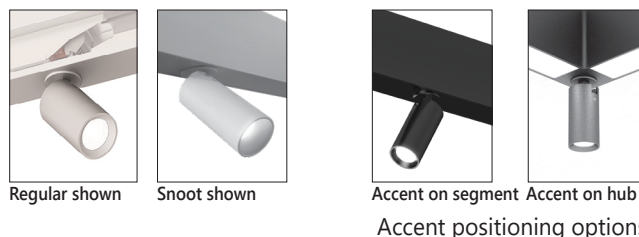

● STENCIL SURFACE WITH ACCENT SECTION VIEW

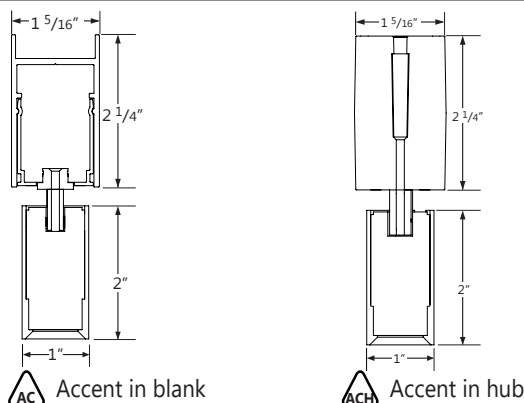

ACCENT EFFICACY

3 Accents /Driver

120V, 21W, 0.18A;
277V, 21.5W, 0.10A.

1 Accent /Driver

120V, 8W, 0.12A;
277V, 8.4W, 0.06A.

NOTE: Configuration of multiple accents with different drivers will change efficacy values.

● PHOTOMETRIC DATA - MICRO LOUVER DIRECT

Micro Louver Narrow Black 600 lm/ft

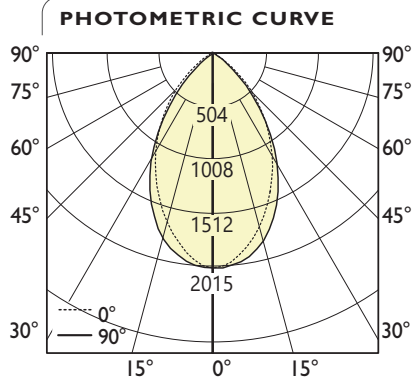

Direct Output: 600 lm/ft
Total Lumens: 2312 lm (for 4ft)
Input Watts: 46.9 W
Efficacy: 49 lm/W

80 CRI shown. For 90 CRI, divide wattage by 0.8 and multiply efficacy by 0.8.
 IES FILE: STSLF-MLNB-600-80-35-4.ies
 TESTED ACCORDING TO IES LM-79-2008

CANDELA DISTRIBUTION

Vertical Angle	Horizontal Angles				
	0	22.5	45	67.5	90
0	2015	2015	2015	2015	2015
5	1970	1974	1980	1992	1994
15	1689	1699	1742	1797	1820
25	1313	1324	1349	1389	1434
35	913	916	899	897	932
45	513	508	469	422	431
55	137	155	145	109	100
65	15	11	7	2	2
75	2	1	1	1	1
85	1	1	1	1	1
90	1	1	1	1	1

ZONAL LUMENS

Zone	Lumens
0	185
0-10	483
10-20	612
20-30	553
30-40	350
40-50	117
50-60	9
60-70	1
70-80	1
80-90	1
90	1

LUMINANCE DATA (cd/m²)

Vertical Angle	Horizontal Angles		
	0	45	90
45	29701	27185	24947
55	9763	10321	7147
65	1425	718	159
75	277	156	142
85	518	396	336

Micro Louver Narrow Grey 600 lm/ft

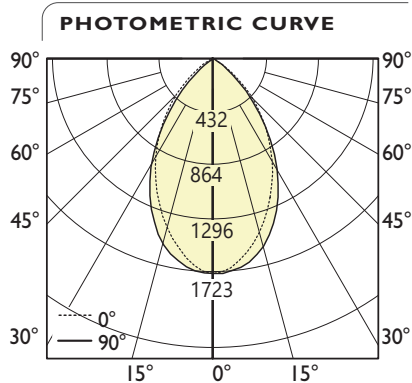

Direct Output: 600 lm/ft
Total Lumens: 2420 lm (for 4ft)
Input Watts: 35.7 W
Efficacy: 68 lm/W

80 CRI shown. For 90 CRI, divide wattage by 0.8 and multiply efficacy by 0.8.
 IES FILE: STSLF-MLNG-600-80-35-4.ies
 TESTED ACCORDING TO IES LM-79-2008

CANDELA DISTRIBUTION

Vertical Angle	Horizontal Angles				
	0	22.5	45	67.5	90
0	1729	1729	1729	1729	1729
5	1692	1696	1704	1715	1717
15	1478	1484	1519	1563	1584
25	1191	1203	1217	1247	1287
35	876	881	869	863	894
45	558	556	524	482	489
55	245	259	241	205	198
65	106	102	92	79	76
75	51	50	44	41	41
85	13	13	14	13	13
90	1	2	1	1	1

ZONAL LUMENS

Zone	Lumens
0	160
0-10	423
10-20	554
20-30	534
30-40	392
40-50	206
50-60	91
60-70	47
70-80	14
80-90	14
90	14

LUMINANCE DATA (cd/m²)

Vertical Angle	Horizontal Angles		
	0	45	90
45	32310	30347	28321
55	17465	17230	14136
65	10260	8893	7401
75	8041	7003	6420
85	6195	6379	6094

i All IES files are available for download at: www.axislighting.com

● PHOTOMETRIC DATA - MICRO LOUVER DIRECT

Micro Louver Wide Black 600 lm/ft

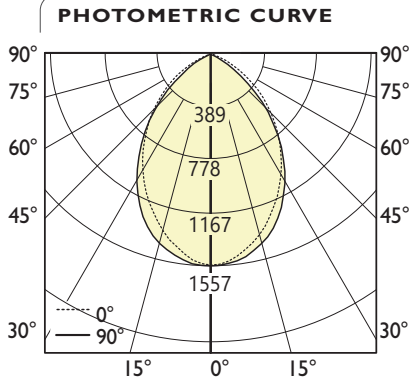

Direct Output: 600 lm/ft
Total Lumens: 2465 lm (for 4ft)
Input Watts: 32.7 W
Efficacy: 75 lm/W

80 CRI shown. For 90 CRI, divide wattage by 0.8 and multiply efficacy by 0.8.
 IES FILE: STSLF-MLWB-600-80-35-4.ies
 TESTED ACCORDING TO IES LM-79-2008

CANDELA DISTRIBUTION					
Vertical Angle	Horizontal Angles				
	0	22.5	45	67.5	90
0	1557	1557	1557	1557	1557
5	1533	1533	1541	1545	1544
15	1382	1385	1407	1438	1446
25	1158	1167	1191	1217	1242
35	904	907	906	912	943
45	636	633	603	582	603
55	372	356	316	273	276
65	124	118	90	60	53
75	6	4	2	2	2
85	2	1	1	1	1
90	1	1	1	1	1

ZONAL LUMENS	
Zone	Lumens
0	
0-10	145
10-20	393
20-30	541
30-40	559
40-50	458
50-60	276
60-70	88
70-80	5
80-90	1
90	

LUMINANCE DATA (cd/m²)			
Vertical Angle	Horizontal Angles		
	0	45	90
45	36841	34945	34945
55	26604	22563	19686
65	11986	8772	5140
75	917	353	272
85	717	492	425

Micro Louver Wide Grey 600 lm/ft

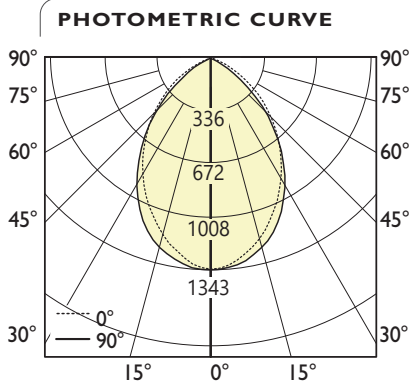

Direct Output: 600 lm/ft
Total Lumens: 2402 lm (for 4ft)
Input Watts: 25.87 W
Efficacy: 93 lm/W

80 CRI shown. For 90 CRI, divide wattage by 0.8 and multiply efficacy by 0.8.
 IES FILE: STSLF-MLWG-600-80-35-4.ies
 TESTED ACCORDING TO IES LM-79-2008

CANDELA DISTRIBUTION					
Vertical Angle	Horizontal Angles				
	0	22.5	45	67.5	90
0	1343	1343	1343	1343	1343
5	1328	1324	1327	1330	1330
15	1205	1204	1218	1231	1240
25	1029	1029	1039	1048	1064
35	827	819	806	799	814
45	611	596	559	529	532
55	392	371	323	276	269
65	179	166	132	100	89
75	52	49	42	38	35
85	14	13	11	9	8
90	1	1	1	1	1

ZONAL LUMENS	
Zone	Lumens
0	
0-10	125
10-20	343
20-30	479
30-40	510
40-50	441
50-60	300
60-70	141
70-80	49
80-90	14
90	

LUMINANCE DATA (cd/m²)			
Vertical Angle	Horizontal Angles		
	0	45	90
45	35413	32387	30844
55	27995	23059	19211
65	17399	12749	8674
75	8183	6665	5578
85	6758	5255	3992

i All IES files are available for download at: www.axislighting.com

● PHOTOMETRIC DATA - DIRECT

Spotless Lens
200 lm/ft

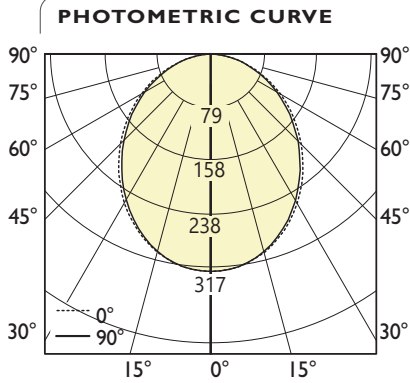

Direct Output: 200 lm/ft
Total Lumens: 800 lm (for 4ft)
Input Watts: 9.1 W
Efficacy: 88 lm/W

80 CRI shown. For 90 CRI, divide wattage by 0.8 and multiply efficacy by 0.8.
IES FILE: STSLF-SO-200-80-35-4.IES
TESTED ACCORDING TO IES LM-79-2008

CANDELA DISTRIBUTION					
Vertical Angle	Horizontal Angles				
	0	22.5	45	67.5	90
0	317	317	317	317	317
5	315	315	315	315	315
15	299	299	299	298	298
25	270	270	268	267	266
35	231	231	228	226	225
45	187	186	183	180	179
55	140	140	137	134	133
65	94	94	92	90	89
75	48	49	49	48	47
85	12	12	12	11	11
90	1	1	1	1	1

ZONAL LUMENS	
Zone	Lumens
0	
0-10	30
10-20	84
20-30	123
30-40	143
40-50	141
50-60	123
60-70	91
70-80	51
80-90	14
90	

LUMINANCE DATA (cd/m²)			
Vertical Angle	Horizontal Angles		
	0	45	90
45	7985	7851	7675
55	7389	7239	7033
65	6701	6567	6363
75	5668	5694	5514
85	4079	4203	3874

Spotless Lens
300 lm/ft

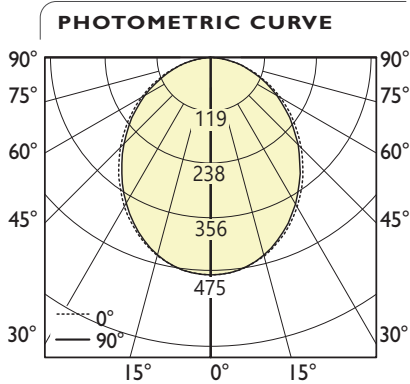

Direct Output: 300 lm/ft
Total Lumens: 1200 lm (for 4ft)
Input Watts: 12.6 W
Efficacy: 95 lm/W

80 CRI shown. For 90 CRI, divide wattage by 0.8 and multiply efficacy by 0.8.
IES FILE: STSLF-SO-300-80-35-4.IES
TESTED ACCORDING TO IES LM-79-2008

CANDELA DISTRIBUTION					
Vertical Angle	Horizontal Angles				
	0	22.5	45	67.5	90
0	475	475	475	475	475
5	472	472	472	472	472
15	449	449	448	447	447
25	405	405	403	400	399
35	346	346	342	338	337
45	280	280	275	271	269
55	210	210	206	202	200
65	140	140	138	135	133
75	73	74	73	72	71
85	18	18	18	17	17
90	1	1	1	1	1

ZONAL LUMENS	
Zone	Lumens
0	
0-10	45
10-20	126
20-30	185
30-40	214
40-50	212
50-60	184
60-70	136
70-80	77
80-90	21
90	

LUMINANCE DATA (cd/m²)			
Vertical Angle	Horizontal Angles		
	0	45	90
45	11978	11776	11513
55	11084	10859	10550
65	10051	9851	9544
75	8502	8542	8271
85	6118	6304	5810

i All IES files are available for download at: www.axislighting.com

● PHOTOMETRIC DATA - DIRECT

Spotless Lens
400 lm/ft

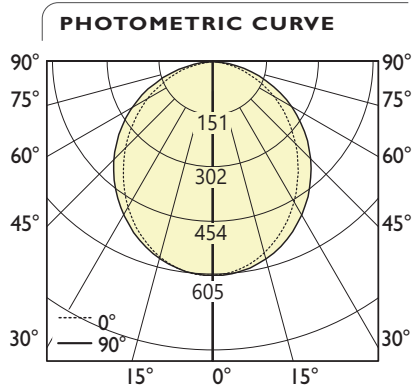

CANDELA DISTRIBUTION					
Vertical Angle	Horizontal Angles				
	0	22.5	45	67.5	90
0	604	604	604	604	604
5	597	597	599	600	601
15	558	560	567	573	576
25	494	499	512	524	529
35	415	422	441	458	466
45	329	337	360	380	390
55	241	249	273	294	303
65	154	161	182	202	209
75	72	78	91	106	112
85	11	13	17	23	25
90	0	0	0	1	0

ZONAL LUMENS	
Zone	Lumens
0	57
0-10	161
10-20	239
20-30	281
30-40	285
40-50	253
50-60	190
60-70	106
70-80	27
80-90	27
90	

LUMINANCE DATA (cd/m²)			
Vertical Angle	Horizontal Angles		
	0	45	90
45	41858	45837	49617
55	37812	42873	47624
65	32769	38735	44638
75	25073	31762	39068
85	11103	17519	25974

Direct Output: 400 lm/ft
Total Lumens: 1600 lm (for 4ft)
Input Watts: 16.01 W
Efficacy: 100 lm/W

80 CRI shown. For 90 CRI, divide wattage by 0.8 and multiply efficacy by 0.8.
 IES FILE: STSLF-SO-400-80-35-4.IES
 TESTED ACCORDING TO IES LM-79-2008

i All IES files are available for download at: www.axislighting.com

● PHOTOMETRIC DATA - ACCENTS

Accent 20 degree

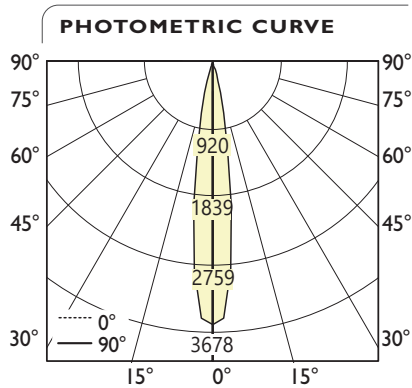

Vertical Angle	Horizontal Angles				
	0	22.5	45	67.5	90
0	3605	3605	3605	3605	3605
5	2668	2516	1376	2760	2863
15	398	366	183	405	422
25	50	48	23	57	53
35	12	11	5	12	12
45	6	6	3	6	6
55	4	4	2	4	4
65	3	3	1	3	3
75	1	1	0	1	1
85	0	0	0	0	0
90	0	0	0	0	0

Zone	Lumens
	0
0-10	131
10-20	29
20-30	8
30-40	4
40-50	4
50-60	3
60-70	1
70-80	0
80-90	0
90	0

Vertical Angle	Horizontal Angles		
	0	45	90
45	16184	7724	16550
55	14208	6951	14208
65	12306	6360	13742
75	5358	3013	6027
85	1986	1005	5958

Total Lumens: 391 lm (for 1 accent)
Input Watts: 7.9 W
Efficacy: 49 lm/W

80 CRI shown. For 90 CRI, divide wattage by 0.8 and multiply efficacy by 0.8.
 IES FILE: Stencil-AC-D20(A17399G-20 DG).IES
 TESTED ACCORDING TO IES LM-79-2008

Accent 35 degree

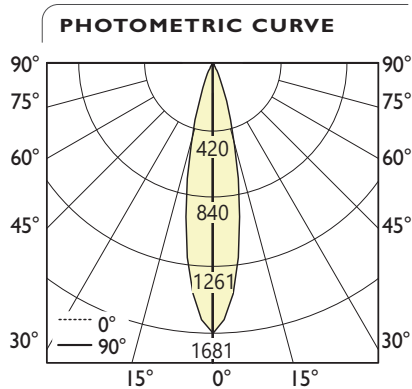

Vertical Angle	Horizontal Angles				
	0	22.5	45	67.5	90
0	1681	1681	1681	1681	1681
5	1442	1453	1453	1455	1453
15	527	518	518	512	506
25	110	109	112	108	105
35	25	25	25	25	24
45	9	9	9	9	9
55	5	5	5	5	5
65	3	3	3	3	3
75	1	1	1	1	1
85	0	0	0	0	0
90	0	0	0	0	0

Zone	Lumens
	0
0-10	145
10-20	55
20-30	17
30-40	7
40-50	5
50-60	3
60-70	1
70-80	0
80-90	0
90	0

Vertical Angle	Horizontal Angles		
	0	45	90
45	30812	31571	30121
55	21803	22482	21803
65	15718	15604	16184
75	4908	4908	5289
85	2236	1684	2236

Total Lumens: 355 lm (for 1 accent)
Input Watts: 6.8 W
Efficacy: 52 lm/W

80 CRI shown. For 90 CRI, divide wattage by 0.8 and multiply efficacy by 0.8.
 IES FILE: Stencil-AC-D35(A18322G-35 DG).IES
 TESTED ACCORDING TO IES LM-79-2008

i All IES files are available for download at: www.axislighting.com

● PHOTOMETRIC DATA - MikroLite 1.0

MikroLite - 35° beam

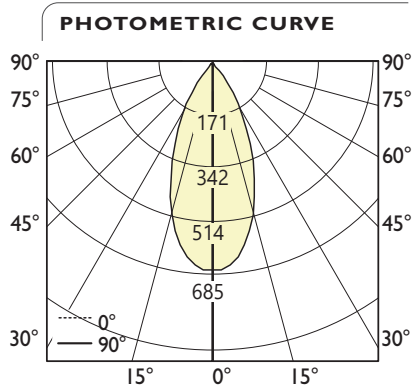

CANDELA DISTRIBUTION

Vertical Angle	Horizontal Angles				
	0	22.5	45	67.5	90
0	685	685	685	685	685
5	664	665	666	667	666
15	514	517	522	521	520
25	292	297	305	301	296
35	119	132	142	132	117
45	15	27	50	27	14
55	2	3	4	3	3
65	0	0	0	0	0
75	0	0	0	0	0
85	0	0	0	0	0
90	0	0	0	0	0

ZONAL LUMENS

Zone	Lumens
0	62
0-10	143
10-20	137
20-30	82
30-40	25
40-50	4
50-60	0
60-70	0
70-80	0
80-90	0
90	0

LUMINANCE DATA (cd/m²)

Vertical Angle	Horizontal Angles		
	0	45	90
45	10042	34267	9679
55	2064	3662	2476
65	0	0	0
75	0	0	0
85	0	0	0

Total Lumens: 452 lm (for 1 accent)
Input Watts: 6.59 W
Efficacy: 69 lm/W

80 CRI shown. For 90 CRI, divide wattage by 0.8 and multiply efficacy by 0.8.
 IES FILE: MKL-D35-A18323G.IES
 TESTED ACCORDING TO IES LM-79-2008

MikroLite - 20° beam

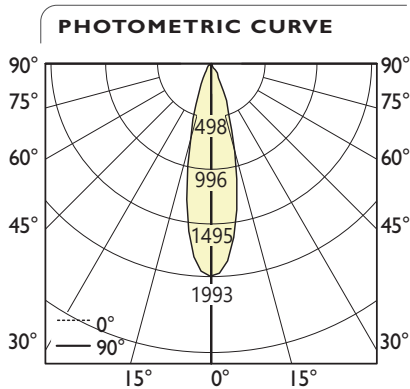

CANDELA DISTRIBUTION

Vertical Angle	Horizontal Angles				
	0	22.5	45	67.5	90
0	1993	1993	1993	1993	1993
5	1859	1830	1831	1837	1835
15	858	863	861	828	843
25	286	288	294	273	266
35	76	88	102	89	71
45	9	15	32	15	9
55	1	1	3	1	1
65	0	0	0	0	0
75	0	0	0	0	0
85	0	0	0	0	0
90	0	0	0	0	0

ZONAL LUMENS

Zone	Lumens
0	159
0-10	225
10-20	122
20-30	49
30-40	13
40-50	2
50-60	0
60-70	0
70-80	0
80-90	0
90	0

LUMINANCE DATA (cd/m²)

Vertical Angle	Horizontal Angles		
	0	45	90
45	192	452	113
55	22	37	14
65	0	1	1
75	0	0	0
85	0	0	0

Total Lumens: 569 lm (for 1 module)
Input Watts: 6.6 W
Efficacy: 86 lm/W

80 CRI shown. For 90 CRI, divide wattage by 0.8 and multiply efficacy by 0.8.
 IES FILE: MKL-D20-A18324G.IES
 TESTED ACCORDING TO IES LM-79-2008

i All IES files are available for download at: www.axislighting.com