

# 4406-30

120V

Catalog #:		Type
Project:		Date
Prepared by:		

## Outdoor Wet Listed Wall Sconce, Energy Star



Brushed Aluminum (BA)



Oil Rubbed Bronze (OB)



Black (BK)

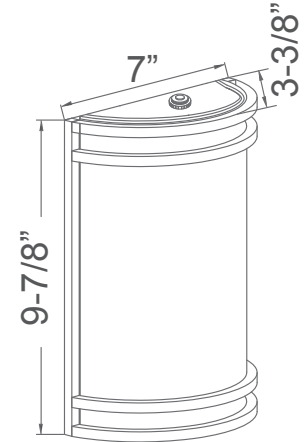

### DESCRIPTION

The ideal choice for outdoor applications for building mounted illumination along pathways or near doorways. This wet listed wall sconce has a white acrylic lens for soft illumination for an elegant style and integral LED for long life. The Energy Star listing and integrated photocell assure increased energy savings.

### DESIGN FEATURES

#### Construction

- Durable steel construction
- 7" W x 9-7/8" H x 3-3/8" D

#### Electrical

- 120V
- Dimmable TRIAC, 10-100%
- 50,000 hour projected life
- 15W, 800lms, 53.33lms/W
- 80 CRI, 3000K
- Operating temperature: -4°F (-20°C) to 104°F (40°C)
- Integrated photocell

#### Lens

- Acrylic lens protects LEDs and diffuses glare while allowing for optimum lumen output

#### Finish

- Available in Brushed Aluminum, Black or Oil Rubbed Bronze

#### Certifications

- cETLus listed for wet location
- Energy Star Listed
- 5 year limited warranty
- ADA Compliant

### ORDERING

Example: 4406-30-BA

Model	Finish
4406-30	
4406-30	-BA : Brushed Aluminum -BK : Black -OB : Oil Rubbed Bronze

TEL: 800.937.6925 | Fax: 800.207.9509 | [www.rplighting.com](http://www.rplighting.com)

Specifications and dimensions subject to change without notice.

