



ANGO

Product Name: Auroral

SKU: Gold: AW-CL17071
 Silver: AW-CL17072
 Copper: AW-CL17073

Electrics: 10' UL/cUL listed cord with 1 x E26 (medium base)
 G40 half mirror bulb (gold, silver or copper) included
 LED LAMP ONLY 20W maximum



Diffuser material: Handworked steel + nickel, gold or copper plating
 Lacquer added to nickel and copper finishes
 Base Material : Hand finished stainless steel

Dimensions:
 X: 19 in (480 mm)
 Y: 9 in (230 mm)
 Z: 19 in (480 mm)
 Weight: 2.4 lbs (1.1 kg)

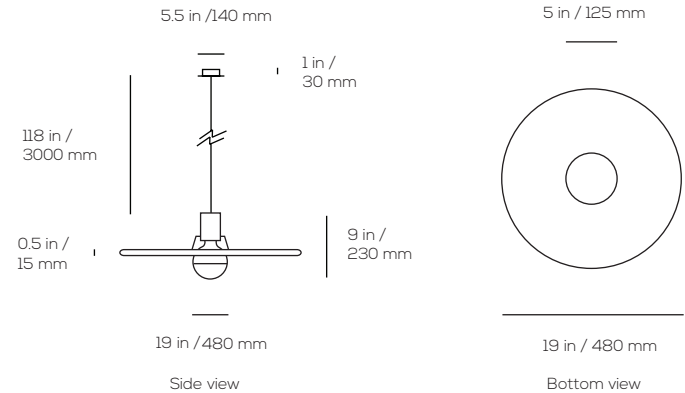

wakaNINE
 North American Distributor

info@wakanine.com
 512. 284. 9672



ANGO

Auroral is made of a hand soldered wire matrix – where nodes of refracted light are apparently suspended in space. Each piece is formed totally free style by hand in welded filigree. There are three finishes: nickel or copper electroplating with a lacquer finish, or 18 karat gold electroplating over the nickel layer.

Lead Time: 4-6 weeks

Cleaning/Maintenance: Lightly vacuum or dust with a dry duster, or very gently wash in warm water.

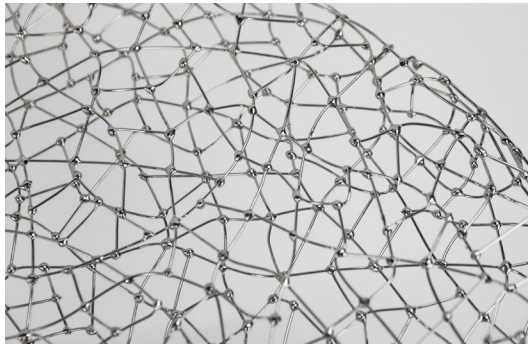

Close up detail of the hand soldered metal filigree.



For Auroral, a G40 half-mirror LED bulb is supplied, which directs the light upward making the fixture glow.



10' of electrical cord, canopy and installation hardware is supplied standard with the product.

Ango fixtures are made with natural materials that have variation in texture and color. The images shown on this page show indicative texture and color. Please contact info@wakanine.com to request materials samples/swatches.



Ango does not manufacture or assemble electrical components utilized in the fixtures. These are sourced from UL/cUL certified manufacturers. As such, Ango shades are hung on UL/cUL certified electrical cordsets and are 100% suitable for commercial installation in North America.

wakaNINE
North American Distributor

info@wakanine.com
512. 284. 9672