



VERSA COMMERCIAL

6" LED COMMERCIAL DOUBLE SIDEKICK WALL WASH NEW CONSTRUCTION

JOB INFORMATION	TYPE:
	CATALOG NO.:
	PROJECT NAME:
	COMMENTS:
PREPARED BY:	

FEATURES

USE OF PRODUCT

The Versa Commercial Double Sidekick Wall Wash Series is the ideal product for energy efficient lighting in Non-IC New Construction applications where double wall washing is required, such as corridors & hallways.

VERSA COMMERCIAL FEATURES

30° Double Sidekick Wall Wash			
Wattage	Lumens	Voltage	CRI
11W	1020 lm	120-277V	93+
16W	1380 lm	120-277V	93+
20W	1590 lm	120-277V	93+
21W	1895 lm	120-277V	93+
30W	2090 lm	120-277V	93+
31W	2440 lm	120-277V	93+
38W	2940 lm	120-277V	93+
45W	3260 lm	120-277V	93+
57W	3840 lm	120-277V	93+

50° Double Sidekick Wall Wash			
Wattage	Lumens	Voltage	CRI
11W	965 lm	120-277V	93+
16W	1225 lm	120-277V	93+
20W	1490 lm	120-277V	93+
21W	1765 lm	120-277V	93+
30W	1945 lm	120-277V	93+
31W	2345 lm	120-277V	93+
38W	2765 lm	120-277V	93+
45W	3100 lm	120-277V	93+
57W	3825 lm	120-277V	93+

Color Temperature: 2700K, 3000K, 3500K, or 4000K
 SDCM: 2 step binning
 Color Rendering Index: 93+ CRI
 R9: 60+
 LED Life: 50,000 hours
 LED Type: Cree LED
 Warranty: 5 year limited warranty

SIDEKICK TECHNOLOGY

Versa Commercial Double Sidekick Wall Wash utilizes angle bending diffuser technology that evenly redirects and distributes light for precision wall washing.

LED ENGINE

LED engine available with CREE LEDs in 2700K, 3000K, 3500K, or 4000K in standard 93+ CRI. 2 Step MacAdam ellipse allows for color consistency between fixtures. LED engine is available in a multitude of optical lens allowing for easy optical control. LED mounted to aluminum heat sink for maximum life output and thermal management.

OPTICAL LENS (Field Replaceable)

Available in 30° and 50° beam angle.

DIMMING

Available in 8 driver selections. (ID) Standard all-inclusive ELV, Triac, and 0-10V dimming driver called Intelligent Drive, 120-277V. (PEQ0) Lutron Hi-Lume Premier Ecosystem 0.1% w/soft on, fade to black dimming, 120-277V. (LDE1) Lutron Hi-Lume 1% Ecosystem with soft on, fade to black dimming, 120-277V. (LTE) Hi-Lume 1% 2-wire, 120V (L3DA) Hi-lume 1% EcoSystem/3-Wire L3D Driver (EEL) eldoLED Eco 1% Dim (0-10V), 120-277V. (EDIO) eldoLED Solo 0.1% Dim(0-10V), 120-277V. (EDID) eldoLED Solo 0.1% Dim(DALI), 120-277V.

EMERGENCY BACKUP

Optional emergency battery available for a minimum of 90 minutes with both integral or remote test switch in 800 or 1700 delivered lumens

VERSATILITY

The Versa Commercial Sidekick series provides for interchangeable wall wash trims in 30° or 50° double wall wash lens also with an assortment of finishes to achieve a particular look. The ability to field install and/or replace various trims makes the Versa Commercial Sidekick Series the most flexible commercial wallwash downlight in the industry.

INSTALLATION

Non-IC housing. Installation must be kept at least 3" away from fixture.

LABELS/COMPLIANCE

-CSA Listed for US and Canada



ORDERING INFORMATION

Series	Lumens	Color Temp	Voltage	Dimming
RVC6DW-30 - 6" Versa Commercial 30° Double Wall Wash	10L - 1020 lm	27 - 2700K	UNV - 120-277V	ID ² Standard all-inclusive ELV, Triac, and 0-10V dimming driver (Intelligent Drive)
	13L - 1380 lm	30 - 3000K	1 - 120V	PEQ0 ³ Lutron Hi-Lume Premier Ecosystem 0.1% w/soft on, fade to black dimming
	15L - 1590 lm	35 - 3500K	3 ¹ - 347V	LDE1 ⁵ Lutron Hi-Lume 1% Ecosystem with soft on, fade to black dimming
	18L - 1895 lm	40 - 4000K		LTE ^{4,5} Hi-Lume 1% 2-wire
	20L - 2090 lm			L3DA - Hi-lume 1% EcoSystem/3-Wire L3D Driver
	24L - 2440 lm			EEL ^{5,6} eldoLED Eco 1% Dim (0-10V)
	29L - 2940 lm			EDIO ^{5,6} eldoLED Solo 0.1% Dim (0-10V)
	32L - 3260 lm			EDID ^{5,6} eldoLED Solo 0.1% Dim (DALI)
	38L - 3840 lm			
RVC6DW-50 - 6" Versa Commercial 50° Double Wall Wash	9L - 965 lm			
	12L - 1225 lm			
	14L - 1490 lm			
	17L - 1765 lm			
	19L - 1945 lm			
	23L - 2345 lm			
	27L - 2765 lm			
	31L - 3100 lm			
38L - 3825 lm				

Double Wall Wash Trim	Frame	Frame Accessories	Options
6TWD - White Double Wall Wash 6TSD - Specular Clear Double Wall Wash 6THD - Haze Double Wall Wash 6TBD - Black Double Wall Wash MTO - Made to Order	FN - New Construction	C - C Channel bar hanger B - Flat bar hanger WJ - Wood joist	ER8 - Emergency Battery with Remote Switch (800 Lumens) ER17 - Emergency Battery with Remote Switch (1700 Lumens) WL - Wet Location

1. Step down transformer required.
2. Intelligent Drive is the standard driver for the Versa Commercial.
3. Driver must not exceed 20W
4. 120V only.
5. Inapplicable to 4000 Lumen offering.
6. Must specify logarithmic or linear eldoLED driver.



www.rayonlighting.com
info@rayonlighting.com

Tel: 323.446.2626
Fax: 323.446.2606

Specification and product availability subject to change without notice

FRAME ACCESSORIES

WJ

Slotted Holes
allow for an
easier installation

4" up to 8" CKOs

Fits up to 26" stud spacings

Plate is offset, allowing for
adjustability with irregular
stud spacing

B

27"

1/2"

Flat Bar Hanger

C

C Channel Bar Hanger

VERSA COMMERCIAL

6" LED COMMERCIAL DOUBLE SIDEKICK WALL WASH
NEW CONSTRUCTION

PROJECT:	
MODEL #:	
LOCATION:	
CONTACT:	

DIMENSIONS

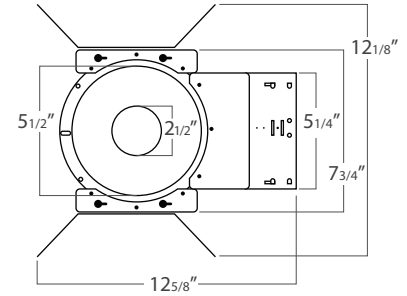
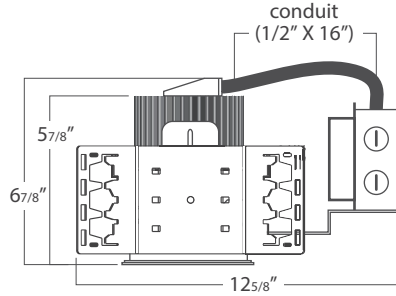
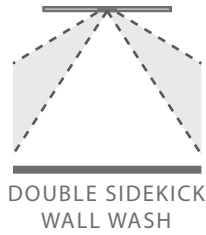

WALL WASH DIMENSIONS

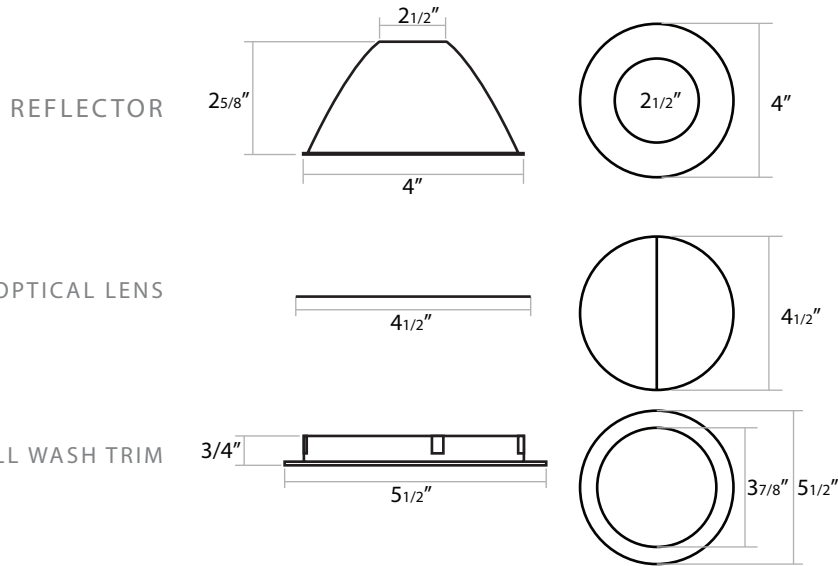

LED HEIGHT INSIDE DOWNLIGHT

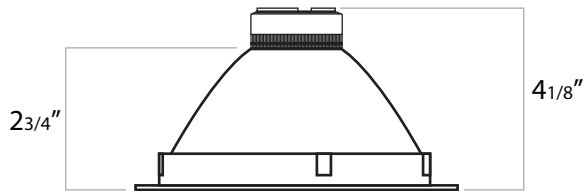

VERSA COMMERCIAL

6" LED COMMERCIAL DOUBLE SIDEKICK WALL WASH
NEW CONSTRUCTION

PROJECT:

MODEL #:

LOCATION:

CONTACT:

ANATOMY

